

■ **Spare parts**
for wheel brakes in
commercial vehicles,
buses and trailers

■ **5th Edition**

This publication is not subject to any update service.
New versions are available in INFORM at
www.wabco-auto.com

■ © copyright WABCO 2008
WABCO
Vehicle Control Systems

The right of amendment is reserved
Version 005/03.08(en)
815 010 041 3

Important safety instructions

Only qualified personnel of a specialist workshop may perform repair work on vehicle safety system devices.

- Always follow the specifications and instructions of the vehicle manufacturer.
- Always comply with the company and national accident prevention/health & safety regulations.
- Use only spare parts approved by WABCO or the vehicle manufacturer.
- Only start the repair after you have read and understood all information required for the repair.
- Additionally required documents: Test Instructions, Spare Parts Sheet, General Notes on Repair and Test (820 001 074 3) to be found at www.wabco-auto.com by entering the product number of the device or the document number in INFORM.
- Test each repaired device – according to test instructions – at appropriate facilities for proper function and leaks.
- When fitting our spare parts, please bear in mind that these have to be fitted without using force. Since braking systems are vital elements in terms of safety, we cannot accept any liability for improper use or installation.
- Our 8 or 10 digit brake or spare part number is provided to clearly identify the wheel brake required for repair.

Third party lining sets and retaining systems

WABCO has noticed that an increasing number of third party suppliers are offering lining sets for our compressed-air disk brakes of the PAN series that do not meet our standards of quality and are not approved by WABCO.

Both the contents and the quality of such repair kits do not match those of our genuine repair kits.

This represents a major safety risk. Please note that claims for remedy of defects and product liability claims may be refused if parts are used that have not been approved by WABCO.

Product warning and patent note:

Layout and function of the WABCO hold-down systems in combination with the original brake linings are protected by patent (EP 0 694 707 B1) for the entire PAN series.

Only WABCO and authorised WABCO partners are permitted to distribute such components. In the event of patent infringement, WABCO reserves the right to sue for damages and an injunction.

Notes:

This brochure only contains an excerpt from all common wheel brakes for commercial vehicles, trailers, and buses and their repair kits and spare parts. You will find this brochure in PDF format and further information in the product catalogue INFORM on the Internet at www.wabco-auto.com or on DVD.

Please note that the material contained herein is for your information only and that vehicle manufacturers may change the technical data for their vehicles (vehicle types) without notifying us, and that errors are possible in spite of the great care we have taken in compiling this document. For this reason we are unable to accept any responsibility for the data on vehicle types, pad and lining dimensions.

If you have any questions on the brochure, brakes, spare parts list, or on brakes and vehicles not listed, please contact us or one of our sales partners in your area who will be happy to help you.

Table of contents

DAF	LF 45 (front and rear axles)	4
	LF 55 (front and rear axles)	5
	LF 55 (front and rear axles)	6
Daimler	Van 207 D to 310 D (front axle)	7
	Van 207 D to 210 (rear axle)	8
	Van 206 D to 307 (rear axle)	9
	Off-road vehicle 230 G to 300 G (front axle)	10
	Van 307 and 308 and Off-road vehicles 230 G to 300 G (rear axle)	11
	Sprinter and Vario (front and rear axles)	12
	Unimog U 400 / U 500	13
	Expanders and readjustments	14
Alexander Dennis	DART Bus	15
EvoBus	(Kässbohrer) Bus S 130 ES to S 328 DT (rear axle)	16
	(Kässbohrer) Bus S 110 to S 300 NC (rear axle)	17
	(Kässbohrer) Bus S 150 to S 200 (rear axle)	18
	(Kässbohrer) Bus S 110 to S 328 DT (rear axle)	19
IVECO	Van Turbo Daily 35-10 to 49-12 Turbo (front axle)	20
	Van Turbo Daily 35-10 to 49-12 (rear axle)	21
	Van Turbo Daily 59-12 (front axle)	22
	Van Turbo Daily 59-12 (rear axle)	23
	Truck Euro Cargo 120 E to 320 E (rear axle)	24
	Truck Euro Cargo Type 115.14 to 145.17 (rear axle)	25
	Truck Euro Cargo Type 120 EL (front axle)	27
	Truck Euro Tech MP 180 E to 440 MP (rear and central axles)	28
	Truck Euro Tech Type 240 E / 260 E and MP 240 to 720	29
	Truck Euro Star LD 240 E to LD 520 E (rear axle)	30
	Truck Euro Star LD 240 E to LD 520 E	31
	Euro Trakker MP 190 E to MP 440 E (front and rear axle)	32
	Euro Trakker MP 190 E to MP 440 E (front and rear axle)	33
	Coach 471 to 580 (front axle)	34
	Coach 471 to 580 (rear axle)	35
Leyland/DAF	SERIES 45 - Roadrunner (front axle)	36
	SERIES 45 - Roadrunner (rear axle)	37
	SERIES 45 - Roadrunner (front axle)	38
	SERIES 45 - Roadrunner (rear axle)	39
	SERIES 55 - Roadrunner (front axle)	40
	SERIES 55 - Roadrunner (front and rear axles)	41
MAN	L 2000 until 12/96 (front axle)	42
	L 2000 from 01/97 and M 2000L from 02/96 (front and rear axles)	43
Neoplan	Bus Types N 116 to N 4021 NF (front axle)	44
	Bus Jet-, Sky-, Space- Trans- and Cityliner (rear axle)	45
	Bus N 8008 and Metroliner (front and rear axles)	47
RENAULT	Renault Midlum 7 - 12 t (front and rear axle)	48
	Renault Midlum 14 - 16 t (front and rear axle)	49
Trailer General	Semi-trailers (19.5" rim)	50
	Semi-trailers (22.5" rim)	51
SAF	Semi-trailers (19.5" rim)	52
	Semi-trailers (22.5" rim)	54
SAMRO/Fontenax	Semi-trailers	56
Schmitz	Semi-trailers	57
SMB	Semi-trailers	58
Cranes	Liebherr, Krupp, Mannesmann-Dematic, Tadano-Faun etc.	59
	Liebherr	64
	Fault finding	65
	Technical information on basic setting of wheel brakes	69



Model	Year of construction
LF 45	from 11 / 2000

Front and rear axle: Sliding calliper compressed-air disc brake PAN 17

Spare Parts List 40 175 070 / 071

Description	WABCO number	DAF number	Pieces	Note
Brake	40 175 070	1403632	1	left brake
Brake	40 175 071	1403633	1	right brake
Brake pads repair kit Contents: Brake linings, hold-down springs, hold-down screws, retainer, sealing plugs, wear indicators, casing clamps	12 999 743VT	1436901	1	per axle* including wear indicators
Repair kit of seals and guide bolts Contents: Protection caps, cheese head screws, guide pins, sealings, bushings	12 999 699VT	1436853	1	per brake
Repair kit sealings actuating unit Contents: Sealings, sealing plugs	640 175 920 2		1	per brake
Brake disc repair kit 7 t front axle	Replacement for: 12 999 811 12 999 756VT	1408670 1408252 1400163	1	per brake
Brake disc repair kit 12 t front axle	Replacement for: 12 999 812 12 999 757VT	1408671 1408253 1403758	1	per brake
Brake disc repair kit Rear axle	Replacement for: 12 999 813 12 999 758VT	1408672 1408254 1400273	1	per brake
Exchange brake (without disc brake pads)	40 175 072 40 175 073	1440500 1440501	1 1	left brake right brake
Tool box	12 851 022		1	

* Replacement must always occur per axle!



Model	Year of construction
LF 55	09 / 2000– 01 / 2003

Front and rear axle: Sliding calliper compressed-air disc brake PAN 19-2

Spare Parts List 40 195 007/008

Description	WABCO number	DAF number	Pieces	Note
Brake	40 195 007	1400072	1	left brake
Brake	40 195 008	1400067	1	right brake
Brake pads repair kit Contents: Brake linings, hold-down springs, hold-down screws, retainer, sealing plugs, wear indicators, casing clamps	12 999 748VT	1440504	1	per axle* including wear indicators
Repair kit of seals and guide bolts Contents: Protection caps, cheese head screws, guide pins, sealings, bushings	12 999 746VT	1440505	1	per brake
Repair kit of brake disc front axle	12 999 760VT	1400069	1	per brake
Repair kit of brake disc rear axle	12 999 759VT	1400284	1	per brake
Exchange brake (without disc brake pads)	40 195 011 40 195 012	1440502 1440503	1 1	left brake right brake
Tool box	12 851 021			

* Replacement must always occur per axle!



Model	Year of construction
LF 55	from 02 / 2003

Front and rear axle: Sliding calliper compressed-air disc brake PAN 19-1^{plus}

Spare Parts List 40 195 043 / 044

Description	WABCO number	DAF number	Pieces	Note
Brake	40 195 043	1407634	1	left brake
Brake	40 195 044	1407635	1	right brake
Brake pads repair kit Contents: Brake linings, hold-down springs, hold-down screws, retainer, sealing plugs, wear indicators, casing clamps	12 999 791	1628064	1	per axle* including wear indicators
Repair kit of seals and guide bolts Contents: Protection caps, cheese head screws, guide pins, sealings, bushings	12 999 776	1628065	1	per brake
Repair kit sealings actuating unit Contents: Sealings, sealing plugs	640 175 920 2		1	per brake
Repair kit of brake disc front axle	12 999 760VT	1400069	1	per brake
Repair kit of brake disc rear axle	12 999 759VT	1400284	1	per brake
Replacement brake PAN 19-1 ^{plus} (without disc brake pads)	40 195 045 40 195 046	1628062 1628063	1 1	left brake right brake
Tool box	12 851 021		1	

* Replacement must always occur per axle!



Front Axle: Hydraulic 4-Piston Fixed Calliper Disc Brake

Spare Parts List

444 F-Ö 2-circuit (207 D, 208, 209 D, 210) **40 444 183/184**

(Spares version for series brake 40,444,103/104)

444 F-Ö 1-circuit (307 D, 308, 309 D, 310) **40 444 149/150**

(Spares version for series brake 40,444,105/106)

T1	kW/PS	Year of construct. 1977
207 D	48/65	-8/82
208	63/85	-8/82
208 D	58/79	-8/82
209 D	65/88	9/82-94
210	77/105	9/82-94
210 D	70/95	9/82-94
307 D	48/65	-8/82
307 D	48/65	9/82-95
308	63/85	-8/82
308 D	58/79	-8/82
308 D	58/79	9/82-95
309 D	65/88	9/82-95
310	77/105	9/82-94
310 D	70/95	9/82-95

Description	WABCO number	Daimler number	Pieces	Note
Brake (2-circuit, electrical wear indicator, painted)	40 444 183	006 421 19 98	1	left brake
Brake (2-circuit, electrical wear indicator, painted)	40 444 184	006 421 20 98	1	right brake
Brake (1-circuit, electrical wear indicator, painted)	40 444 149	667 420 31 01	1	left brake
Brake (1-circuit, electrical wear indicator, painted)	40 444 150	667 420 32 01	1	right brake
Brake pads repair kit	12 999 165VT	001 420 14 20	1	per axle*
Contents: brake pads	or 12 999 221VT	601 420 87 20	1	per axle*
Seals repair kit	12 999 197VT	000 420 68 83	1	per brake
Contents: Sealing rings				
Pistons repair kit	12 999 097VT	000 421 57 83	2/4**	per brake
Repair kit of pistons (with plastic insert on wheel side) Contents: 1 pistons	12 999 179VT	000 420 14 51	2/0**	per brake
Hold-down spring	13 304 042	000 421 47 91	1	per brake
Hold down pin	12 728 001	000 991 32 60	1	per brake

* Replacement must always occur per axle!

** depending on the brake design



T1	kW/PS	Year of construct. 1977
207 D	48/65	-8/1982
207 D	53/72	-2/1995
208	63/85	-8/1982
208	58/79	-2/1995
208 D	58/79	-8/1982
208 D	58/79	-2/1995
209 D	65/88	-2/1995
210	70/95	-2/1995

Rear axle: Hydraulic Servo Drum Brake with Parking Brake Facility 230 × 35 SM-Öm

**Spare Parts List 10 230 022/023
10 230 024/025**

Description	WABCO number	Daimler number	Pieces	Note
Brake (with manual adjustment)*	10 230 022	601 420 24 02	1	left brake
Brake (with manual adjustment)*	10 230 023	601 420 25 02	1	right brake
Brake (with automatic adjustment)*	10 230 024	601 420 26 02	1	left brake
Brake (with automatic adjustment)*	10 230 025	601 420 27 02	1	right brake
Brake shoes repair kit normal thickness Contents: Brake shoes with pad	12 999 433VT	601 430 09 22	1	per axle**
Springs repair kit Contents: Springs, spring seat, pin, washer	12 999 020VT	002 586 39 42	1	per axle**
Adjuster for 10 230 022/023 (manually)	12 603 114VT	000 420 30 38	1	per brake
Adjuster for 10 230 024/025 (automatically)	12 603 115VT	000 420 31 38	1	per brake
Thrust piece	13 229 101	000 423 00 16	1	per brake

* Complete brakes are no longer available.

** Replacement must always occur per axle!

Daimler Van 407 to 410D
(from year of construction 1977)

270 × 80 SM-Öm



Model	Year of construction
407-410 D	from 1977

Front Axle: Hydraulic Servo Drum Brake with Parking Brake Facility 270 × 80 SM-Öm

Spare Parts List 10 270 132/133

Description	WABCO number	Daimler number	Pieces	Note
Brake*	10 270 132	611 420 02 02	1	left brake
Brake*	10 270 133	611 420 03 02	1	right brake
Brake shoes repair kit normal thickness Contents: Brake shoes with pad	12 999 439VT	611 420 90 20	1	per axle**
Springs repair kit Contents: Pressure and tension springs, spring seat, pin, washer	12 999 118VT	611 421 00 92	1	per axle**
Adjuster (automatically), (old no. 12 603 130)	16 001 041	000 420 38 38	1	per brake
Thrust piece	13 229 074	000 423 01 16	1	per brake

* Complete brakes are no longer available.

** Replacement must always occur per axle!



Model
230 GE
280 GE
240 GD
250 GD
290 GD
300 GD
G 230
G 300
G 300 D
500 GE AMG

Front Axle: Hydraulic 4-Piston Fixed Calliper Disc Brake 444 F-Ö

Spare Parts List 40 444 239/240 (1-circuit, painted)

(Spares version for series brake 40 444 241/242)

Description	WABCO number	Daimler number	Pieces	Note
Brake (electrical wear indicator, automatic adjuster)	40 444 239	461 420 09 02	1	left brake
Brake (electrical wear indicator, automatic adjuster)	40 444 240	461 420 10 02	1	right brake
Alternative for:				
Brake (electrical wear indicator, automatic adjuster)	40 444 221	000 420 80 01	1	left brake
Brake (electrical wear indicator, automatic adjuster)	40 444 222	000 420 81 01	1	right brake
Brake pads repair kit	12 999 800	004 420 14 20	1	per axle*
Contents: brake pads	12 999 221VT or 12 999 165VT	601 420 87 20 001 420 14 20	1 1	per axle*
Seals repair kit	12 999 197VT	000 420 68 83	1	per brake
Contents: Sealing rings				
Pistons repair kit	12 999 137VT	000 421 59 83	4	per brake
Contents: 1 pistons				
Hold-down spring	13 304 042	000 421 47 91	1	per brake*
Hold down pin	12 728 001	000 991 32 60	1	per brake*

* Replacement must always occur per axle!



Rear axle: Hydraulic Servo Drum Brake with Parking Brake Facility
260 × 55 SM-Öm

**Spare Parts List 10 260 058/059
10 260 039/040**

For off-road vehicles with silicone brake fluid

Model	kW/PS	Year of construct.
307 D	48/65	77–8/82
307 D	48/65	82–2/95
308	63/85	77–8/82
308 D	58/79	77–8/82
308 D	58/79	92–2/95
309 D	65/88	82–2/95
310	77/105	82–2/95
310 D	70/95	82–2/95
230 G		
240 G		
280 G		
300 G		

Description	WABCO number	Daimler number	Pieces	Note
Brake*	10 260 058	460 420 50 02	1	left brake
Brake*	10 260 059	460 420 51 02	1	right brake
Brake (with silicone brake fluid)*	10 260 039	460 420 35 02	1	left brake
Brake (with silicone brake fluid)*	10 260 040	460 420 36 02	1	right brake
Brake shoes repair kit normal thickness Contents: Brake shoes with pad	12 999 436VT	461 420 00 20	1	per axle**
Springs repair kit Contents: Springs, spring seat, pin, washer	12 999 027VT	002 586 32 42	1	per axle**
Adjuster (automatic)	12 603 115VT	000 420 31 38	1	per brake
Thrust piece	13 229 101	000 423 00 16	1	per brake

* Complete brakes are no longer available.

** Replacement must always occur per axle!



Mod.	kW/PS	Year of construction
408 D	58/ 79	1995–04/2002
410 D	75/102	1995–04/2002
412 D	90/122	1995–04/2002
414	105/143	1995–04/2002
512 D (Vario)		1995–04/2002
VW LT 46		

Front and rear axle: Hydraulic sliding calliper disc brake 244 V-Ö

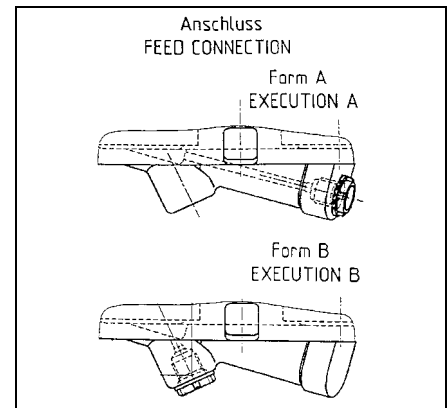

Spare Parts List 40 244 009/010 (A)
40 244 017/018 (B)

Description	WABCO number	Daimler-Number	Pieces	Note
Brake left*	40 244 009	904 420 08 01 2D0 615,105 B**	1	Form A
Brake right*	40 244 010	904 420 09 01 2D0 615,106 B**	1	Form A
Replacement for brake left*	40 244 001	902 420 11 01	1	Form A / 04/2002
Brake right*	40 244 002	902 420 12 01	1	Form A / 04/2002
Brake left*	40 244 017	904 420 18 01	1	Form B
Brake right*	40 244 018	904 420 19 01	1	Form B
Brake pads repair kit Contents: Brake linings, hold-down springs, screws	12 999 541VT	002 420 41 20 2D0 698 151 A**	1	per axle***
Brake calliper repair kit left* Contents: Brake calliper with piston, sealing ring, protective caps, hexagonal head screws	12 999 719VT 12 999 765	001 420 86 83 002 420 32 83	1 1	Form A Form B
Brake calliper repair kit right* Contents: Brake calliper with piston, sealing ring, protective cap, hexagonal head screws	12 999 720VT 12 999 766	001 420 87 83 002 420 33 83	1 1	Form A Form B
Bolts repair kit Contents: Guide pins, bolt protective caps, hexagonal head screws	12 999 543VT	000 420 04 82 2D0 698 647**	1	per brake
Wear indicator	13 480 023	901 540 00 17 or 901 540 01 17	1	per brake

* In the case of Vario 512 D the brakes on the front axle are installed side-inverted.

** VW LT 46

*** Replacement must always occur per axle!



Model	Year of construction
U 500	from 03/2000
U 400	from 03/2000

Front and rear axle: Sliding calliper compressed-air disc brake 1300 V-G

Spare Parts List 40 130 001/002 (from 03/2000)
40 130 003/004 (from 03/2000)

replaced by

Spare Parts List 40 130 009/010 (from 02/2002)
40 130 011/012 (from 02/2002)

Description	WABCO number	Daimler number	Pieces	Note
Brake	40 130 001	A4054200101	1	front axle left
Brake	40 130 002	A4054200201	1	front axle right
Brake	40 130 003	A4054200301	1	rear axle left
Brake	40 130 004	A4054200401	1	rear axle right
Brake	40 130 009	A4054200701	1	front axle left
Brake	40 130 010	A4054200801	1	front axle right
Brake	40 130 011	A4054200901	1	rear axle left
Brake	40 130 012	A4054201001	1	rear axle right
Brake pads repair kit Contents: Brake linings, pins, hold-down springs, sealing plugs, wear indicator, casing clamps, retaining ring	12 999 732VT	A4054200020	1	per axle* including wear indicators
Seals repair kit, rubber parts Contents: Sealing rings, protection caps, cover, pressure springs, screws, sealing plugs	12 999 733VT	A4054200083	1	per brake
Sliding bush repair kit Contents: Protection cap, bushing, screw, cover, guide pins, sealings	12 999 734VT	A4054200076	1	per brake
Brake lever repair kit Contents: Angle joint, screw, brake lever, nut	12 999 735VT	A4054200042	1	per brake
Exchange brake (without disc brake pads)	40 130 007	A4054210498	1	front axle left
	40 130 008	A4054210598	1	rear axle left front axle right rear axle right

* Replacement must always occur per axle!

Adjuster Daimler



Adjustments for Van Type 207 to 407 and Off-Road Vehicles 230 G to 300 G

Vehicle type	Brake size Rear axle	Adjuster old version Daimler No.	Adjuster new version Daimler No.	a) Installation dimension b) Internal width
208	230 × 35	601 420 20 38 (automatically)	601 420 24 38 Replacement: 12 603 186VT (automatically)	a) 82 mm b) 5 mm
207 / 307	270 × 80			
308	260 × 55			
230 G / 240 G	260 × 55			
280 G / 300 G	260 × 55			
407 811 truck	300 × 85 300 × 100 300 × 120	670 420 03 38	670 420 05 38 Replacement: 12 603 187VT (automatically)	a) 85 mm b) 7 mm



Simplex Expanding Wedge Drum Brake 360 × 170 ZE

**Spare Parts List 10 360 077 / 078
10 360 079 / 080**

Description	WABCO number	DENNIS number	Pieces	Note
Brake	10 360 077	654 975	1	front axle left
Brake	10 360 078	654 974	1	front axle right
Brake	10 360 079	654 973	1	rear axle left
Brake	10 360 080	654 972	1	rear axle right
Dust shield	13 201 148	654 812-1	1	per brake
Brake shoes with pad	12 258 430VT	654 975-1	2	per brake*
Brake shoes without pad	12 155 493	654 812-9	2	per brake*
Brake pad normal size	13 057 624	-	2	per brake*
Rivet	13 601 001	653 251-4	36	per brake
Springs repair kit Contents: Springs, leaf spring, washers	12 999 623VT	-	1	per axle*
Leaf springs (separate)	13 304 064	654 812-21	2	per brake*
Expander	12 739 075VT	654 812-13	1	per brake
Leaf spring repair kit Contents: Springs, washers, protective caps	12 999 418VT	654 812-17	1	per brake
Wedge repair kit Contents: Piston, springs, roller, wedge, etc.	12 999 402VT	654 812-15	1	per brake
Adjuster repair kit Contents: Pressure springs, ring, nut etc.	12,999 403VT	654 812-16	1	per brake
Seals repair kit Contents: Washer, protective cap, spiral spring	12 999 404VT	654 812-18	1	per brake

* Replacement must always occur per axle!

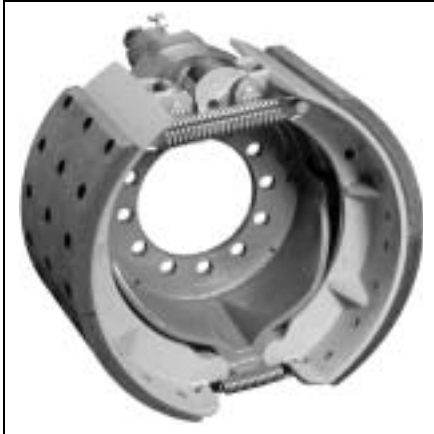

Model	Year of construction
S 130 ES	1982–1986
SG 180	1973–1983
S 180 N	1975–1989
S 200 N	1974–1989
S 211 H	08/1976–1983
S 212 H	08/1976–9/78
S 213 H, HD	08/1976–9/78
S 215 H, HD	08/1976–9/78
S 215 HDH	1994–
S 216 HDS	
S 228 DT	
S 328 DT	

N = trailing axle

Rear axle:
Mechanical Simplex Drum Brake (S-Cam Brake) 410 × 140 Z-G

Spare Parts List 10 410 781/782 (Trailing Axle)

Description	WABCO number	EvoBus number	Pieces	Note
Brake	10 410 781	8.285.362.000	1	left brake
Brake	10 410 782	8.828.530.000	1	right brake
Replacement for				
Brake	10 410 264	8.285.194.000	1	left brake
Brake	10 410 265	8.285.195.000	1	right brake
Brake shoe without pad	12 155 243VT	8.282.000.798	2	per brake*
Brake pad	13 057 682	8.285.194.122	4	per axle
Brake pad	13 057 683	8.285.360.355	4	per axle
Rivet	13 601 002	0.107.338.210	64	per axle
Roller repair kit Contents: Roller, bolts, washer	12 999 002VT	–	1	per brake
Seals repair kit Contents: Rotary shaft seal, bush, washer, ring	12 999 055VT	–	1	per brake
Springs repair kit Contents: Tension springs	12 999 003VT	–	1	per brake*

* Replacement must always occur per axle!

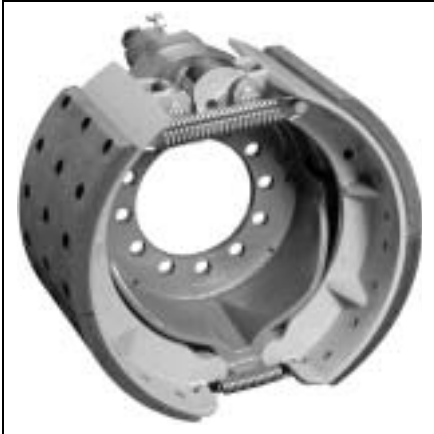

Rear axle:
Mechanical Simplex Drum Brake (S-Cam Brake) 410 × 160 Z-G

Model	Year of construct.
S 110, S 120, E, EV	08/1978
S 130, S 140, E, ES	1979–
S 210, HD, HDV	1983–88
S 211, S 212 HUE	1983–
S 213, S 214	1983–
S 215, UL; SL	1983–
S 211 H, S212 H	10/1987–
S 213 H, HD	10/1987
S 215 H, HD	10/1987
S 215 HDS, HDH	1980–83
S 216 HDS	1980–83
SG 219 SL, SG 221 UL	1984–
SG 228 DT	1984–
S 309	1991–
S 300 NC (City-Bus)	

Spare Parts List 10 410 308/309

Description	WABCO number	EvoBus number	Pieces	Note
Brake*	10 410 308	8.285.196.000	1	left brake
Brake*	10 410 309	8.285.197.000	1	right brake
Replacement for Brake*	10 410 229	8.285.232.000	1	left brake
Brake*	10 410 230	8.285.233.000	1	right brake
Brake shoes without pad	12 155 419VT	8.285.049.024	2	per brake**
Roller repair kit Contents: Roller, bolts, washer	12 999 112VT	8.285.049.051	1	per brake
Seals repair kit Contents: Rotary shaft seal, bush, washer, ring	12 999 121VT	8.285.049.063	1	per brake
Springs repair kit Contents: Tension springs	12 999 114VT	8.285.049.053	1	per brake**

* Complete brakes are no longer available.

** Replacement must always occur per axle!

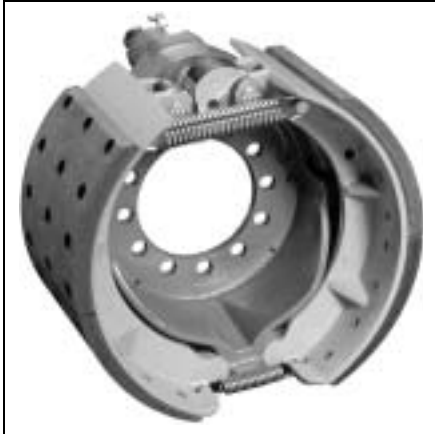

Model	Year of construction
S 150 E	1968–1989
S 210, HD, HDV	1989–
S 212 H	10/1978–1983
S 213 H, HD	10/1978–1983
S 215 H, HD	10/1978–1983
S 180	1975–1989
S 200	1974–1989
S 228 DT	
S 309	

Rear axle:
Mechanical Simplex Drum Brake (S-Cam Brake) 410 × 180 Z-G

Spare Parts List 10 410 783/784

Description	WABCO number	EvoBus number	Pieces	Note
Brake	10 410 783	8.285.366.000	1	left brake
Brake	10 410 784	8.285.367.000	1	right brake
Replacement for				
Brake	10 410 470	8.285.317.000	1	left brake
Brake	10 410 471	8.285.318.000	1	right brake
Brake shoe with pad	12 258 545VT		2	per brake*
Roller repair kit	12 999 112VT	8.285.049.051	1	per brake
Contents: Roller, bolts, washer	12 999 520VT	8.285.530.599	1	per brake
Seals repair kit	12 999 113VT	8.285.057.052	1	per brake
Contents: Rotary shaft seal, bush, washer, ring				
Springs repair kit	12 999 114VT	8.285.049.053	1	per brake*
Contents: Tension springs				

* Replacement must always occur per axle!

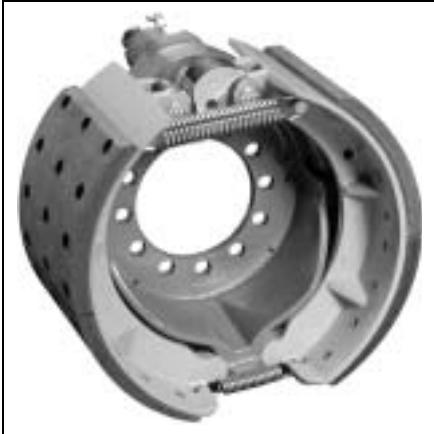

Rear axle:
Mechanical Simplex Drum Brake (S-Cam Brake) 410 × 220 Z-G

Model	Year of construct.
S 110, S 120, E, EV	03/1979–
S 130 S, ES	1982–86
S 140 E, ES	1979–
S 150 E	03/1979
S 210, S 250	10/1978–
S 211 H, S 212 H	10/1978–
S 213 H, HD, HDH	10/1978–
S 215 H, HD, HDH	10/1978–
S 215 HDS	1980–83
S 216 HDS, HDSI	1980–
S 211, S 212 HUE	1983–
S 213, S 214,	1983–
S 215, UL, SL	1983–
S 217 HD, HDH	
SG 219 SL, SG 221 UL	1984–
SG 228 DT	1984–
S 300 N, NC (City-Bus)	1991–
S 312 HD,	1994–
S 315 HD, HDH	
S 328 DT	

Spare Parts List 10 410 789/790

Description	WABCO number	EvoBus number	Pieces	Note
Brake*	10 410 789	8.285.510.000	1	left brake
Brake*	10 410 790	8.285.511.000	1	right brake
Replacement for brake	10 410 574	8.285.368.000	1	left brake
Brake	10 410 575	8.285.369.000	1	right brake
or	10 410 646	8.285.479.000	1	left brake
Brake	10 410 647	8.285.480.000	1	right brake
or	10 410 650	8.285.481.000	1	left brake
Brake	10 410 651	8.285.482.000	1	right brake
or	10 410 741	8.285.534.000	1	left brake
Brake	10 410 742	8.285.535.000	1	right brake
Brake show with lining	on request	–	2	per brake**
Brake lining	on request	–	4	per axle**
Brake lining	on request	–	4	per axle**
Rivet	on request	–	96	per axle**
Roller repair kit	Steel brake shoes 12 999 112VT	8.285.049.051	1	per brake
Contents: Roller, bolts, washer	Cast brake shoes 12 999 520VT	8.285.530.599	1	per brake
Seals repair kit	12 999 113VT	8.285.057.052	1	per brake
Contents: Rotary shaft seal, bush, washer, ring				
Springs repair kit	12 999 114VT	8.285.049.053	1	per brake**
Contents: Tension springs				
Brake shafts	13 161 255VT	8.285.057.049	1	left brake
	13 161 256VT	8.285.058.050	1	right brake

* Complete brakes are no longer available
** Replacement must always occur per axle!



Model	kW/PS	Year of construction
35-10 T	76/103	90-07/1998
35-12 T	90/122	90-07/1998
40-10 TW	76/103	89-07/1998
49-10 T	76/103	90-07/1998
49-12 T	90/122	90-07/1998

T = Turbo
TW = Four-wheel (4 × 4)

Front Axle: Hydraulic 4-Piston Fixed Calliper Disc Brake 444 F-Ö

Spare Parts List 40 444 223/224

(1-circuit, electrical wear indicator)

Description	WABCO number	IVECO number	Pieces	Note
Brake 1-circuit, electrical wear indicator	40 444 223	9946 5304	1	right brake
Brake 1-circuit, electrical wear indicator	40 444 224	9946 5302	1	left brake
Replacement for:				
Brake 1-circuit, electrical wear indicator	40 444 191	485 5709	1	right brake
Brake 1-circuit, electrical wear indicator and	40 444 192	485 5708	1	left brake
Brake 1-circuit, electrical wear indicator	40 444 205	9840 7736	1	right brake
Brake 1-circuit, electrical wear indicator	40 444 206	9840 7735	1	left brake
Brake pads repair kit Contents: brake pads and wear indicator	12 999 646VT	190 6430	1	per axle* including wear indicators
Replacement for	12 999 248VT	190 6040	1	per axle* including wear indicators
Seals repair kit Contents: Sealing rings, protection cap	12 999 197VT	812 4729	1	per brake
Pistons repair kit Contents: Piston with plastic insert	12 999 179VT	9315 6105	4	per brake
Hold-down spring	13 304 042	9319 3603	1	per brake
Hold down pin	12 728 001	812 2714	1	per brake

* Replacement must always occur per axle!



Model	kW/PS	Year of construct.
35-10 T	76/103	1990–
35-12 T	90/122	1990–
40-10 TW	76/103	1989–
49-10 T	76/103	1990–
49-12 T	90/122	1990–

T = Turbo
TW = Four-wheel (4 × 4)

Rear axle: Hydraulic Servo Drum Brake with Parking Brake Facility 270 × 80 SM-Öm

Spare Parts List 10 270 258/259

Description	WABCO number	IVECO number	Pieces	Note
Brake	10 270 258	9943 6612	1	left brake
Brake	10 270 259	9943 6613	1	right brake
Replacement for				
Brake	10 270 246	9844 9332	1	left brake
Brake	10 270 247	9844 9334	1	right brake
and				
Brake	10 270 211	484 6034	1	left brake
Brake	10 270 212	484 6035	1	right brake
Brake shoe repair kit normal size Contents: Brake shoes with pads	12 999 529VT	190 6377	1	per axle*
Brake pad repair kit Contents: Pads and rivet	12 999 663VT	190 6380	1	per axle*
Springs repair kit Contents: Pressure and tension springs, spring seats, pins	12 999 287VT	812 4934	1	per brake*
Adjuster repair kit Contents: Tension spring, screw	12 999 288VT	812 4935	1	per brake
Adjuster (automatically)	16 001 042	9319 2155	1	per brake
Wheel cylinder	16 120 001	9315 5720	1	per brake
Thrust piece	13 229 074	812 2289	1	per brake

* Replacement must always occur per axle!



Model	kW/PS	Year of construct.
59-12 T	90/122	1992

Front Axle: Hydraulic 4-Piston Fixed Calliper Disc Brake 450 F-Ö

Spare Parts List 40 450 013/014

(1-circuit, electr. wear indicator)

Description	WABCO number	IVECO number	Pieces	Note
Brake 1-circuit, electrical wear indicator	40 450 013	9946 5473	1	right brake
Brake 1-circuit, electrical wear indicator	40 450 014	9946 5472	1	left brake
Replacement for:				
Brake 1-circuit, electrical wear indicator	40 450 007	9843 8402	1	right brake
Brake 1-circuit, electrical wear indicator	40 450 008	9843 8401	1	left brake
Brake pads repair kit Contents: brake pads and wear indicator	12 999 563VT	190 6183	1	per axle* including wear indicators
Seals repair kit Contents: Sealing rings	12 999 199VT	9316 1181	1	per brake
Pistons repair kit Contents: Piston	12 999 324VT	9316 0387	1	per brake
Hold down spring	13 304 041	9316 0388	1	per brake
Hold down pin	12 728 003	9316 0389	1	per brake

* Replacement must always occur per axle!



Model	kW/PS	Year of construct.
59-12 T	90/122	1992

Rear axle: Hydraulic Servo Drum Brake with Parking Brake Facility 310 × 100 SM-Öm

Spare Parts List 10 310 009/010

Description	WABCO number	IVECO number	Pieces	Note
Brake	10 310 009	9845 2377	1	left brake
Brake	10 310 010	9845 2378	1	right brake
Brake shoe repair kit Contents: Brake shoes with pads	12 999 420VT	190 6196	1	per axle*
Brake pad repair kit normal size Contents: Linings, rivets, wear indicator	12 999 412VT	190 6197	1	per axle*
Springs repair kit Contents: Tension and pressure springs, safety plate, eye hole	12 999 359VT	9316 1195	1	per brake*
Adjuster repair kit Contents: Tension spring, screw	12 999 321VT	9316 1196	1	per brake
Adjuster (automatically)	16 001 014	485 1782	1	per brake
Wheel cylinder	16 923 004	9845 2387	1	per brake
Thrust piece	13 229 123	716 5209	1	per brake

* Replacement must always occur per axle!



Model	kW/PS
120 E15	105/143
120 E18	130/177
120 E23	167/227
130 E15	105/143
130 E18	130/177
130 E23	167/227
150 E15	105/143
150 E18	130/177
150 E23	167/227
150 E27	196/266
210 E23	
250 E23	
320 E23	

Rear axle: Simplex Expanding Wedge Drum Brake 360 × 170 ZE

Spare Parts List 10 360 105/106

Description	WABCO number	IVECO number	Pieces	Note
Brake from 05/1999	10 360 105	50038 1595	1	left brake
	10 360 106	50038 1596	1	right brake
Replacement for brake from 11/1993–05/1999	10 360 089	9943 3037	1	left brake
	10 360 090	9943 3038	1	right brake
and brake 09/1991–11/1993	10 360 053	483 2962	1	left brake
	10 360 054	483 2963	1	right brake
Brake shoe repair kit Contents: Brake shoes with pads	12 999 469VT	190 6361	1	per axle*
Brake pad repair kit normal size Contents: Pad, rivet	12 999 470VT	190 6221	1	per axle*
Springs repair kit (for brake 10 360 053/054) Contents: Tension springs, retainers, pressure springs	12 999 356VT	9316 1183	1	per brake*
Springs repair kit (for brake 10 360 089/090, 10 360 105/106) Contents: Tension springs, leaf springs	12 999 623VT	9316 1954	1	per axle*
Expander	12 739 075VT	9316 3525	1	per brake
Leaf spring repair kit Contents: Springs, washers, protective caps	12 999 418VT	9316 1254	1	per brake
Wedge repair kit Contents: Piston, springs, roller, wedge, etc.	12 999 402VT	9316 1267	1	per brake
Adjuster repair kit Contents: Pressure springs, ring, nut etc.	12,999 403VT	9316 1268	1	per brake
Seals repair kit Contents: Washer, protective cap, spiral spring	12 999 404VT	9316 1257	1	per brake

* Replacement must always occur per axle!



Model
115.14
115.17
135.14
135.17
145.17

Rear axle: Simplex Expanding Wedge Drum Brake 360 × 170 ZE

Chassis No.: up to 117447 10 360 011/012 (7170376/377)
 117448 to 129581 10 360 005/006 (4814390/391)
 from 129582 to 31/08/1994 10 360 023/024 (4838552/553)

Spare Parts List 10 360 023/024

Description	WABCO number	IVECO number	Pieces	Note
Brake*	10 360 023	483 8552	1	left brake
Brake*	10 360 024	483 8553	1	right brake
Brake shoe repair kit Contents: Brake shoes with pad	12 999 347VT	190 6128	1	per axle**
Brake pad repair kit Contents: Pads, rivets	12 999 229VT	190 6000 190 6397	1	per axle**
Springs repair kit Contents: Tension springs, retainers, pressure springs	12 999 356VT	93161183	1	per brake**
Expander	12 739 048VT	819 0221	1	per brake
Wedge repair kit	12 999 134VT	812 4814	1	per brake
Adjuster repair kit	12 999 135VT	812 4815	1	per brake
Seals repair kit	12 999 011VT	812 4031	1	per brake

* Complete brakes are no longer available.
 ** Replacement must always occur per axle!



Model
115.14
115.17
135.14
135.17
145.17

Rear axle: Simplex Expanding Wedge Drum Brake 360 × 170 ZE

Spare Parts List 10 360 097/098 (from 01/09/1994)

Description	WABCO number	IVECO number	Pieces	Note
Brake	10 360 097	190 8484	1	left brake
Brake	10 360 098	190 8485	1	right brake
Brake shoe repair kit Contents: Brake shoes with pad	12 999 469VT	190 6361	1	per axle*
Pad repair kit Contents: Pads, rivets	12 999 470VT	190 6221	1	per axle*
Springs repair kit Contents: Extension springs, leaf springs, screws, washers	12 999 623VT	9316 1954	1	per axle*
Expander	12 739 077VT	9319 4132	1	per brake
Leaf spring repair kit Contents: Springs, washers, protective caps	12 999 418VT	9316 1254	1	per brake
Wedge repair kit Contents: Pistons, springs, roller, wedge, etc.	12 999 134VT	812 4814	1	per brake
Adjuster repair kit Contents: Pressure springs, ring, nut etc.	12,999 403VT	9316 1268	1	per brake
Seals repair kit Contents: Washer, protective cap, spiral spring	12 999 404VT	9316 1257	1	per brake

* Replacement must always occur per axle!



Model	kW/PS
120 EL 15	105 / 143
120 EL 18	130 / 177
120 EL 21	167 / 227

Front and rear axle: Sliding calliper compressed-air disc brake PAN 17

Spare Parts List 40 175 058 / 059

Description	WABCO number	IVECO number	Pieces	Note
Brake (from 03/1999)	40 175 058	50032 8232	1	left brake
Brake (from 03/1999)	40 175 059	50032 8234	1	right brake
Brake pads repair kit Contents: Brake linings, hold-down springs, hold-down screws, retainer, sealing plugs, wear indicators, casing clamps	12 999 698VT	190 6467 299 6430	1	per axle* including wear indicators
Repair kit of seals and guide bolts Contents: Protection caps, cheese head screws, guide pins, sealings, bushings	12 999 699VT	4253 6957	1	per brake
Brake discs repair kit Contents: Brake discs	12 999 728VT	190 6466	1	per axle
Repair kit sealings actuating unit Contents: Sealings, sealing plugs	640 175 920 2		1	per brake
Exchange brake (without disc brake pads)	40 175 072 40 175 073		1 1	left brake right brake
Tool box	12 851 022		1	

* Replacement must always occur per axle!

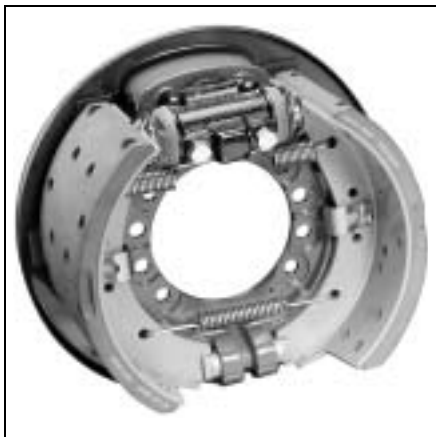

Model	Year of construct.
MP 180 E34/38/42	9/1992–
MP 190 E34/38/42	9/1992–
MP 240 E38/42	9/1992–
MP 260 E38/42	9/1992–
MP 400 E34/38/42	9/1992–
MP 440 E34/38/42/52	9/1992–
MP 190 Off Road	9/1992–
MP 360 Off Road	9/1992–
MP 400 Off Road	9/1992–
MP 720 Off Road	9/1992–

Rear axle: Simplex Expanding Wedge Drum Brake 410 × 200 ZE

MP = Multi Purpose/Heavy-duty series

Spare Parts List 10 410 839/840 from 01/05/1999

Description	WABCO number	IVECO number	Pieces	Note
Brake	10 410 839	4102 5289	1	left brake
Brake	10 410 840	4102 5290	1	right brake
Replacement for brake (up to 30/04/1999)	10 410 804	4102 5327	1	left brake
Brake (up to 30/04/1999)	10 410 805	4102 5328	1	right brake
Brake (up to 31/12/1995)	10 410 615	4210 4441	1	left brake
Brake (up to 31/12/1995)	10 410 616	4210 4442	1	right brake
Brake (from 01/08/1995)	10 410 765	4102 2641	1	left brake
Brake (from 01/08/1995)	10 410 766	4102 2642	1	right brake
Brake shoe repair kit	12 999 711VT	299 1759	1	per axle*
Contents: Brake shoes with lining	12 999 561VT	190 6227	1	per axle*
Replacement for:				
Brake pad repair kit normal size	12 999 712VT	299 1760	1	per axle*
Contents: Brake linings	12 999 568VT	190 6202	1	per axle*
Replacement for:				
Wear indicator	13 480 042	4253 0550	1	per brake
Ring (normal size)	13 701 083	4253 0551	1	per brake
Ring (oversize 1)	13 701 086	4253 0606	1	per brake
Ring (oversize 2)	13 701 085	4103 5564	1	per brake
Rivet	13 601 001	296 1590	56	per brake
Springs repair kit	12 999 573VT	9316 1872	1	per axle*
Contents: Leaf springs, tension springs, fillister socket head screws, washers				
Expander	12,739 076VT	9316 3355	1	per brake
Leaf spring repair kit	12 999 418VT	9316 1254	1	per brake
Contents: Springs, washers, protective caps				
Wedge repair kit	12 999 410VT	9316 1768	1	per brake
Contents: Piston, roller, wedge, etc.				
Adjuster repair kit	12 999 411VT	9316 1256	1	per brake
Contents: Ring, nut, screw, etc.				
Seals repair kit	12 999 404VT	9316 1257	1	per brake
Contents: Washer, protective cap, spiral spring				

* Replacement must always occur per axle!



Model		Year of constr.	Model		Year of constr.
240 E38/42/52	N	92–	MP 380 Off Road	V	
260 E 52	H	92–	MP 400 Off Road	V	
MP 240 E38/42	Z	9/92–	MP 440 Off Road	V, H	
MP 260 E38/42	H	9/92–	MP 720 Off Road	V	
MP 400 E38/42	Z	9/92–	H = 2. rear axle		
MP 440 E34/38/42/52	N	9/92–	N = trailing axle		
MP 190 Off Road	V		V = front axle		
MP 260 Off Road	V, H		Z = intermediate axle		

Front Axle: Simplex Expanding Wedge Drum Brake 410 × 180 ZE

Spare Parts List 10 410 837/838 (4102 5287/5288) from 01/05/1999

Description	WABCO number	IVECO number	Pieces	Note
Brake	10 410 837	4102 5287	1	left brake
Brake	10 410 838	4102 5288	1	right brake
Replacement for brake (up to 30/04/1999)	10 410 802	4102 5325	1	left brake
Brake (up to 30/04/1999)	10 410 803	4102 5326	1	right brake
Brake (up to 31/12/1995)	10 410 613	4210 4437	1	left brake
Brake (up to 31/12/1995)	10 410 614	4210 4438	1	right brake
Brake (from 01/08/1995)	10 410 763	4102 2639	1	left brake
Brake (from 01/08/1995)	10 410 764	4102 2640	1	right brake
Brake shoe repair kit	12 999 709VT	299 1755	1	per axle*
Contents: Brake shoes with lining	12 999 562VT	190 6226	1	per axle*
Replacement for:				
Brake pad repair kit normal size	12 999 710VT	299 1756	1	per axle*
Contents: Brake linings	12 999 567VT	190 6201	1	per axle*
Replacement for:				
Wear indicator	13 480 042	4253 0550	1	per brake
Ring (normal size)	13 701 083	4253 0551	1	per brake
Ring (oversize 1)	13 701 086	4253 0606	1	per brake
Ring (oversize 2)	13 701 085	4103 5564	1	per brake
Rivet	13 601 001	296 1590	56	per brake
Springs repair kit	12 999 573VT	9316 1872	1	per axle*
Contents: Leaf springs, extension springs, screws, washers				
Expander	12,739 076VT	9316 3355	1	per brake
Leaf spring repair kit	12 999 418VT	9316 1254	1	per brake
Contents: Springs, washers, protective caps				
Wedge repair kit	12 999 410VT	9316 1768	1	per brake
Contents: Piston, roller, wedge, etc.				
Adjuster repair kit	12 999 411VT	9316 1256	1	per brake
Contents: Ring, nut, screw, etc.				
Seals repair kit	12 999 404VT	9316 1257	1	per brake
Contents: Washer, protective cap, spiral spring				

* Replacement must always occur per axle!



Model
LD 240 E42/52
LD 380 E
LD 400 E52
LD 420 E
LD 440 E42/52
LD 470 E
LD 520 E

Rear axle:
Simplex Expanding Wedge
Drum Brake 410 × 200 ZE

Types LD 380 to LD 520
also have axle configurations
6 × 2, Trak 6 × 2 and Twir 6 × 2.

Spare Parts List 10 410 839/840 from 01/05/1999

Description	WABCO number	IVECO number	Pieces	Note
Brake	10 410 839	4102 5289	1	left brake
Brake	10 410 840	4102 5290	1	right brake
Replacement for:				
Brake (from 01.01.96 to 30.04.99)	10 410 804	4102 5327	1	left brake
Brake (from 01.01.96 to 30.04.99)	10 410 805	4102 5328	1	right brake
Brake shoe repair kit	12 999 711VT	299 1759	1	per axle*
Contents: Brake shoes with pad Replacement for	12 999 561VT	190 6227	1	per axle*
Brake pad repair kit normal size	12 999 712VT	299 1760	1	per axle*
Contents: brake pads Replacement for	12 999 568VT	190 6202	1	per axle*
Wear indicator	13 480 042	4253 0550	1	per brake
Ring (normal size)	13 701 083	4253 0551	1	per brake
Ring (oversize 1)	13 701 086	4260 0606	1	per brake
Ring (oversize 2)	13 701 085	4103 5564	1	per brake
Rivet	13 601 001	296 1590	56	per brake
Springs repair kit	12 999 573VT	9316 1872	1	per axle*
Contents: Leaf springs, tension springs, fillister socket head screws, washers				
Expander	12,739 076VT	9316 3355	1	per brake
Leaf spring repair kit	12 999 418VT	9316 1254	1	per brake
Contents: Springs, washers, protective caps				
Wedge repair kit	12 999 410VT	9316 1768	1	per brake
Contents: Piston, springs, roller, wedge, etc.				
Adjuster repair kit	12 999 411VT	9316 1256	1	per brake
Contents: Ring, nut, screw, etc.				
Seals repair kit	12 999 404VT	9316 1257	1	per brake
Contents: Washer, protective cap, spiral spring				

* Replacement must always occur per axle!

Front Axle: Simplex Expanding Wedge Drum Brake 410 × 180 ZE

Spare Parts List 10 410 837/838 from 01/05/1999

Description	WABCO number	IVECO number	Pieces	Note
Brake	10 410 837	4102 5287	1	left brake
Brake	10 410 838	4102 5288	1	right brake
Replacement for:				
Brake (up to 30/04/1999)	10 410 802	4102 5325	1	left brake
Brake (up to 30/04/1999)	10 410 803	4102 5326	1	right brake
Brake (up to 31/12/1995)	10 410 613	4210 4437	1	left brake
Brake (up to 31/12/1995)	10 410 614	4210 4438	1	right brake
Brake (up to 01/08/1995)	10 410 763	4102 2639	1	left brake
Brake (up to 01/08/1995)	10 410 764	4102 2640	1	right brake
Brake shoe repair kit	12 999 709VT	299 1755	1	per axle*
Contents: Brake shoes with pad Replacement for	12 999 562VT	190 6226	1	per axle*
Brake pad repair kit normal size	12 999 710VT	299 1756	1	per axle*
Contents: brake pads Replacement for	12 999 567VT	190 6201	1	per axle*
Wear indicator	13 480 042	4253 0550	1	per brake
Ring (normal size)	13 701 083	4253 0551	1	per brake
Ring (oversize 1)	13 701 086	4260 0606	1	per brake
Ring (oversize 2)	13 701 085	4103 5564	1	per brake
Rivet	13 601 001	296 1590	56	per brake
Springs repair kit	12 999 573VT	9316 1872	1	per axle*
Contents: Leaf springs, tension springs, fillister socket head screws, washers				
Expander	12,739 076VT	9316 3355	1	per brake
Leaf spring repair kit	12 999 418VT	9316 1254	1	per brake
Contents: Springs, washers, protective caps				
Wedge repair kit	12 999 410VT	9316 1768	1	per brake
Contents: Piston, springs, roller, wedge, etc.				
Adjuster repair kit	12 999 411VT	9316 1256	1	per brake
Contents: Ring, nut, screw, etc.				
Seals repair kit	12 999 404VT	9316 1257	1	per brake
Contents: Washer, protective cap, spiral spring				

* Replacement must always occur per axle!



Heavy-duty construction vehicles

Model	kW/PS
MP 190 E	
MP 340 E34	259/345
MP 340 E37	272/370
MP 340 E42	309/420
MP 380 E34	259/345
MP 410 E37	272/370
MP 410 E42	309/420
MP 440 E	

Front and rear axle: Simplex Expanding Wedge Drum Brake 410 × 180 ZE

Spare Parts List 10 410 837/838 from 01/05/1999

Description	WABCO number	IVECO number	Pieces	Note
Brake	10 410 837	4102 5287	1	left brake
Brake	10 410 838	4102 5288	1	right brake
Replacement for:brake (up to 30/04/1999)	10 410 802	4102 5325	1	left brake
Brake (up to 30/04/1999)	10 410 803	4102 5326	1	right brake
Brake (up to 31/12/1995)	10 410 613	4210 4437	1	left brake
Brake (up to 31/12/1995)	10 410 614	4210 4438	1	right brake
Brake (from 01/08/1995)	10 410 763	4102 2639	1	left brake
Brake (from 01/08/1995)	10 410 764	4102 2640	1	right brake
Brake shoe repair kit	12 999 709VT	299 1755	1	per axle*
Contents: Brake shoes with liningReplacement for:	12 999 562VT	190 6226	1	per axle*
Brake pad repair kit normal size	12 999 710VT	299 1756	1	per axle*
Contents: Brake linings Replacement for:	12 999 567VT	190 6201	1	
Wear indicator	13 480 042	4253 0550	1	per brake
Ring (normal size)	13 701 083	4253 0551	1	per brake
Ring (oversize 1)	13 701 086	4260 0606	1	per brake
Ring (oversize 2)	13 701 085	4103 5564	1	per brake
Rivet	13 601 001	296 1590	56	per brake
Springs repair kit	12 999 573VT	9316 1872	1	per axle*
Contents: Leaf springs, tension springs, fillister socket head screws, washers				
Expander	12,739 076VT	9316 3355	1	per brake
Leaf spring repair kit	12 999 418VT	9316 1254	1	per brake
Contents: Springs, washers, protective caps				
Wedge repair kit	12 999 410VT	9316 1768	1	per brake
Contents: Piston, springs, roller, wedge, etc.				
Adjuster repair kit	12 999 411VT	9316 1256	1	per brake
Contents: Ring, nut, screw, etc.				
Seals repair kit	12 999 404VT	9316 1257	1	per brake
Contents: Washer, protective cap, spiral spring				

* Replacement must always occur per axle!

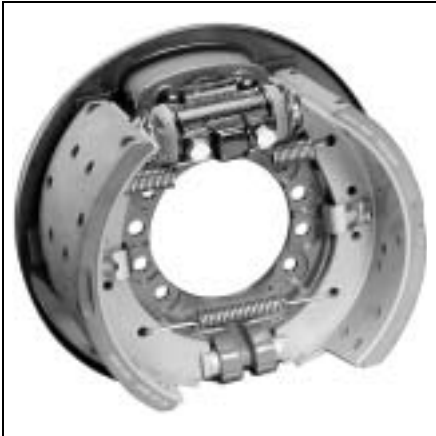

Front and rear axle: Simplex Expanding Wedge Drum Brake 410 × 200 ZE

Spare Parts List 10 410 839/840 from 01/05/1999

Description	WABCO number	IVECO number	Pieces	Note
Brake	10 410 839	4102 5289	1	left brake
Brake	10 410 840	4102 5290	1	right brake
Replacement for:				
Brake (from 01/01/1996 to 30/04/1999)	10 410 804	4102 5327	1	left brake
Brake (from 01/01/1996 to 30/04/1999)	10 410 805	4102 5328	1	right brake
Brake shoe repair kit (per axle)	12 999 711VT	299 1759	1	per axle*
Contents: Brake shoes with lining	12 999 561VT	190 6227	1	per axle*
Replacement for:				
Brake pad repair kit normal size	12 999 712VT	299 1760	1	per axle*
Contents: Brake linings	12 999 568VT	190 6202	1	per axle*
Replacement for:				
Wear indicator	13 480 042	4253 0550	1	per brake
Ring (normal size)	13 701 083	4253 0551	1	per brake
Ring (oversize 1)	13 701 086	4260 0606	1	per brake
Ring (oversize 2)	13 701 085	4103 5564	1	per brake
Rivet	13 601 001	296 1590	56	per brake
Springs repair kit	12 999 573VT	9316 1872	1	per axle*
Contents: Leaf springs, tension springs, fillister socket head screws, washers				
Expander	12,739 076VT	9316 3355	1	per brake
Leaf spring repair kit	12 999 418VT	9316 1254	1	per brake
Contents: Springs, washers, protective caps				
Wedge repair kit	12 999 410VT	9316 1768	1	per brake
Contents: Piston, springs, roller, wedge, etc.				
Adjuster repair kit	12 999 411VT	9316 1256	1	per brake
Contents: Ring, nut, screw, etc.				
Seals repair kit	12 999 404VT	9316 1257	1	per brake
Contents: Washer, protective cap, spiral spring				

* Replacement must always occur per axle!



Model	Year of construction
471-10.20	1984–1988
471-12.20	1984–1988
480-10.21	1988–
480-12.21	1988–
580-10.21	1988–
580-12.22	1988–

Front Axle: Hydraulic 4-Piston Fixed Calliper Disc Brake 485 F-Ö

Spare Parts List 40 485 128/129

Description	WABCO number	IVECO number	Pieces	Note
Brake	40 485 128	4210 4799	1	left brake
Brake	40 485 129	4210 4800	1	right brake
replacement for				
Brake	40 485 126	486 0052	1	left brake
Brake	40 485 127	486 0051	1	right brake
Brake pads repair kit	12 999 235VT	190 6216	1	per axle*
Contents: brake pads				
Pistons repair kit	12 999 162VT	812 4437	2	per brake
Contents: 2 pistons				
Seals repair kit	12 999 076VT	812 4438	2	per brake
Contents: Sealing rings				

* Replacement must always occur per axle!



Model	Year of construction
471-10.20	1984–1988
471-12.20	1984–1988
4.801.021	1988–
4.801.221	
5.801.021	1988–
5.801.221	

Rear axle: Duplex Expanding Wedge Drum Brake 410 × 200 DE

Spare Parts List 10 410 629/630

Description	WABCO number	IVECO number	Pieces	Note
Brake	10 410 629	483 5518	1	left brake
Brake	10 410 630	483 5519	1	right brake
Brake shoe repair kit	12 999 336VT	190 6086	1	per axle
Tension springs	13 301 197	812 1450	2	per brake*
Expander complete for 10 410,629	12 739 078VT	4253 3923	2	per brake
Expander complete for 10 410 630	12 739 079VT	4253 3924	2	per brake
Wedge repair kit Contents: Piston, springs, roller, wedge, etc.	12 999 407VT	4254 1737	1	per brake
Adjuster repair kit Contents: Ring, nut, screw, etc.	12 999 408VT	4254 1736	1	per brake
Seals repair kit Contents: Washer, protective cap, spiral spring	12 999 453VT	4254 1738	1	per brake

* Replacement must always occur per axle!



Model	Year of construct.
FA 600, 800 CN (DAF)	1987–2001
FA 45.120, C6	1991–2001
FA 45.130, C6, C8	1991–2001
FA 45.150, C8	1991–2001
FA 45.160, C8	1991–2001
Roadrunner Range	
6.10, 6.12	1987–1991
6.13, 6.15	1990–1991
8.10, 8.12., 8.15	1987–1991
8.13	1990–1991

Front Axle: Hydraulic 4-Piston Fixed Calliper Disc Brake 456 F-Ö

Spare Parts List 40 456 033/034

Description	WABCO number	DAF/Leyland number	Pieces	Note
Brake	40 456 033	1203033	1	left brake
Brake	40 456 034	1203032	1	right brake
Brake pads repair kit Contents: brake pads	12 999 325VT	FBU 9177	1	per axle*
Pistons repair kit Contents: 1 pistons	12 999 117VT	FBU 4666	4	per brake
Seals repair kit Contents: Protection cap, sealing rings	12 999 116VT	FBU 1076	1	per brake
Fluid pipe repair kit Contents: Fluid pipes	12 999 195VT	FBU 4667	1	per brake
Leaf spring	13 304 038	FBU 3480	1	per brake
Bleeding valve	16 200 051	FBU 4664	3	per brake
Dust cap for bleeding valve	16 200 041	FBU 1082	3	per brake
Pin	12 728 008	FBU 1408	1	per brake
Brake disc	13 162 041	AMPB 889	1	per brake
Replacement for	13 162 018	PAK 5513	1	per brake

* Replacement must always occur per axle!



Rear axle: Hydraulic Expanding Wedge Drum Brake with mech. additional actuation 325 × 100 Z-Öm

Model	Year of construct.
FA 600, 800 CN (DAF)	1987–2000
FA 45.120, C6	1991–2000
FA 45.130, C6, C8	1991–2000
FA 45.150, C8	1991–2000
FA 45.160, C8	1991–2000
Roadrunner Range	
6.10, 6.12	1987–1991
6.13, 6.15	1990–1991
8.10, 8.12., 8.15	1987–1991
8.13	1990–1991

Spare Parts List 10 325 580/581

Description	WABCO number	DAF/Leyland number	Pieces	Note
Brake	10 325 580	AMPB 282 HJJ 5649	1	left brake
Brake	10 325 581	AMPB 283 HJJ 5648	1	right brake
Replacement for:				
Brake	10 325 541	1203447	1	left brake
Brake	10 325 542	1253446	1	right brake
Brake back plate	12 170 662	FBU 5139	1	per left brake
Brake back plate	12 170 663	FBU 5140	1	per right brake
sealing plugs	13 826 009	FBU 1072	5	per brake
Brake shoes repair kit (left brake) Contents: Brake shoes with pad	12 999 656VT	AMPB 289	1	per brake left*
Brake shoes repair kit (right brake) Contents: Brake shoes with pad	12 999 657VT	AMPB 294	1	per brake right*
Brake pad repair kit Contents: Pad, rivet	12 999 328VT	–	1	per axle*
Wheel cylinder	16 138 023	FBU 3730	1	per brake
Adjuster (automatically)	12 603 176VT	FBU 1065	1	per brake
Bellows (for the adjuster)	13 227 085	FBU 1066	1	per brake
Tension spring (on wheel cylinder)	13 301 190	FBU 1068	2	per brake
Tension spring (on the adjuster)	13 301 259	AMPB 094	1	per brake
Pressure spring	13 302 104	FBU 1070	2	per brake

* Replacement must always occur per axle!



Front Axle: Hydraulic 4-Piston Fixed Calliper Drum Brake 465 F-Ö

Model	Year of construct.
FA 1000	1987
FA 1005 (DAF)	
FA 45.130, C9	1991–2001
FA 45.150, C9	1991–2001
FA 45.150, C11	1991–2001
FA 45.160, C9	1991–2001
FA 45.160, C11	1991–2001
FA 45.180, C11	1991–2001
FA 45.210, C11	1991–2001
FA 45.512 (10 t)	1991–2001
Roadrunner Range	
10.12, 10.13	1987–1991
10.15	1987–1991

Spare Parts List 40 465 019/020

Description	WABCO number	DAF/Leyland number	Pieces	Note
Brake	40 465 019	ACU 9383	1	left brake
Brake	40 465 020	ACU 9384	1	right brake
Brake pads repair kit Contents: brake pads	12 999 325VT	BBU 8177	1	per axle*
Pistons repair kit Contents: Piston	12 999 212VT	FBU 4632	2	per brake
Seals repair kit Contents: Sealing rings	12 999 141VT	FBU 1298	1	per brake
Fluid pipe	12 627 054	FBU 1300	1	per brake
Fluid pipe	12 627 055	FBU 1299	1	per brake
Leaf spring	13 304 037	FBU 1056	1	per brake
Bleeding valve	16 200 083	FBU 1081	3	per brake
Dust cap for bleeding valve	16 200 041	FBU 1082	3	per brake
Pin	12 728 013	FBU 4067	1	per brake
Brake disc	13 162 042	AMPB 887	1	per brake
Replacement for	13 162 016	PAK 3546	1	per brake

* Replacement must always occur per axle!



Rear axle: Hydraulic Expanding Wedge Drum Brake with mech. additional actuation 325 × 150 Z-Öm

Model	Year of construct.
FA 1000	1987
FA 1005 (DAF)	
FA 45.130, C9	1991–2001
FA 45.150, C9	1991–2001
FA 45.150, C11	1991–2001
FA 45.160, C9	1991–2001
FA 45.160, C11	1991–2001
FA 45.180, C11	1991–2001
FA 45.210, C11	1991–2001
FA 45.512 (10 t)	1991–2001
Roadrunner Range	
10.12, 10.13	1987–1991
10.15	1987–1991

Spare Parts List 10 325 584/585

Description	WABCO number	DAF/Leyland number	Pieces	Note
Brake	10 325 584	AMPB 286 HJJ 5653	1	left brake
Brake	10 325 585	AMPB 287 HJJ 5652	1	right brake
Replacement for:				
Brake	10 325 566	1257614	1	left brake
Brake	10 325 567	1257615	1	right brake
Brake back plate	12 170 680	FBU 8471	1	per left brake
Brake back plate	12 170 681	FBU 8472	1	per right brake
sealing plugs	13 826 009	FBU 1072	5	per brake
Brake shoes repair kit (left brake) Contents: Brake shoes with pad	12,999 658VT	AMPB 288	1	per brake left*
Brake shoes repair kit (right brake) Contents: Brake shoes with pad	12,999 659VT	AMPB 295	1	per brake right*
Brake pad repair kit Contents: Pad, rivet	12 999 331VT	–	1	per axle*
Wheel cylinder	16 144 018	FBU 3731	1	per brake
Adjuster (automatically)	12 603 176VT	FBU 1065	1	per brake
Bellows (for the adjuster)	13 227 085	FBU 1066	1	per brake
Tension spring (on wheel cylinder)	13 301 190	FBU 1068	2	per brake
Tension spring (on the adjuster)	13 301 259	AMPB 094	1	per brake
Pressure spring	13 302 105	FBU 1061	2	per brake

* Replacement must always occur per axle!



Model	Year of construction
FA 50	up to 1995
FA 55	1995–2001

Front Axle: Sliding calliper compressed-air disc brake 1600 V-G

Spare Parts List 40 160 015/016

Description	WABCO number	DAF/Leyland number	Pieces	Note
Brake	40 160 015	AMPB 005	1	left brake
Brake	40 160 016	AMPB 006	1	right brake
Replacement for:				
Brake	40 160 005	AMPA 048	1	left brake
Brake	40 160 006	AMPA 049	1	right brake
Brake pads repair kit Contents: Brake linings, hold-down springs, pins, sealing plugs, KL-clips, support, wear indicator	12 999 665VT	AMPA 694	1	per axle*
Pistons repair kit Contents: Piston, screws, sealings, pin, sealing plug	12 999 549VT 12 999 550VT	AMPA 139 AMPA 140	1 1	per left brake per right brake
Seals repair kit Contents: Sealings, screws, compression spring	12 999 552VT	AMPA 141	1	per brake
Springs repair kit Contents: Leaf springs, retaining ring, sealing plug, retainer	12 999 553VT	AMPA 247	1	per brake
Guide shaft repair kit Contents: Guide pins, bushings, sealings, screws, caps	12 999 547VT 12 999 548VT	AMPA 135 AMPA 138	1 1	per left brake per right brake
Retaining parts repair kit Contents: KL clip, retainer	12 999 607VT	AMPA 693	1	per brake
Guide shaft repair kit Contents: Guide pin, bushings	12 999 551VT	AMPA 137	1	per brake
Brake disc	13 162 043	AMPB 860	1	per brake
Replacement for	13 162 027	AMPB 481	1	per brake
	13 162 020	AMPA 014	1	per brake

* Replacement must always occur per axle!

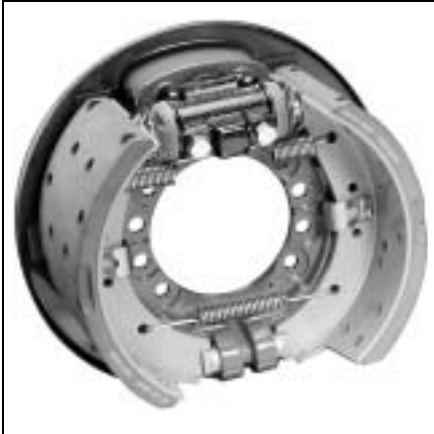

Model	Year of construction
FA 50	up to 1995
FA 55	1995–2001

Rear axle: Simplex Expanding Wedge Drum Brake 360 × 170 ZE

Spare parts List from 1995: **10 360 081/082**
from 1997: **10 360 103/104**

Description	WABCO number	DAF/Leyland number	Pieces	Note
Brake (front axle) U.K. only (FA 50)	10 360 063	AXU 0059	1	left brake
Brake (front axle) U.K. only (FA 50)	10 360 064	AXU 0058	1	right brake
Brake (rear axle) U.K. only (FA 50)	10 360 061	AXU 0061	1	left brake
Brake (rear axle) U.K. only (FA 50)	10 360 062	AXU 0060	1	right brake
Brake (rear axle)	10 360 081	HJJ 3693	1	left brake
Brake (rear axle)	10 360 082	HJJ 3694	1	right brake
Brake (rear axle)	10 360 103	HJJ 5313	1	left brake
Brake (rear axle)	10 360 104	AMPB 009 HJJ 5314 AMPB 010	1	right brake
Dust shield	13 201 148	FBU 9110	1	per brake
Brake shoes repair kit Contents: 4 Brake shoes with pad	12 999 718VT	AMPB 017	1	per axle*
Springs repair kit	12 999 727VT	AMPB 694	1	per axle*
Leaf spring	13 304 029	FBU 9116	2	per brake
Expander	12 739 075VT	FBU 9121	1	per brake
Leaf spring repair kit Contents: Springs, washers, protective caps	12 999 418VT	FBU 7499	1	per brake
Wedge repair kit Contents: Piston, springs, roller, wedge, etc.	12 999 402VT	FBU 9123	1	per brake
Adjuster repair kit Contents: Pressure springs, ring, nut etc.	12,999 403VT	HBU 2663	1	per brake
Seals repair kit Contents: Washer, protective cap, spiral spring	12 999 404VT	FBU 7502	1	per brake

* Replacement must always occur per axle!



Model
L 2000
L 20-25
L 33-36

for identification:
Chassis number
MWA **L20** zzz yyyy

Front Axle: Sliding calliper compressed-air disc brake 1000 V-G

Spare Parts List 40 100 005 / 006

Description	WABCO number	MAN number	Pieces	Note
Brake	40 100 005	81.50804-6049	1	left brake
Brake	40 100 006	81.50804-6048	1	right brake
Disc brake pads repair kit normal strength Contents: Brake linings, leaf springs, pins, sealing plug	12 999 631VT optional	81.50820-6011	1	per axle*
Replacement for	12 999 629VT	81.50820-6009	1	
	12 999 482VT	81.50804-6028	1	
Disc brake pads repair kit oversize Contents: Brake linings, leaf springs, pins, sealing plug	12 999 632VT optional	81.50820-6012	1	per axle*
Replacement for	12 999 630VT	81.50820-6010	1	
	12 999 515VT	81.50800-6010	1	
Guide bolts and seals repair kit Contents: guide pins, rotary shaft seal, cover, protection caps, bushings, screws, compression springs, O-rings	12 999 729VT	81.50800-6023	1	per axle
Exchange brake (without brake pads)	40 100 001	81.50804-9017	1	left brake
		or 81.50804-6017	1	
	40 100 002	81.50804-9018	1	right brake
		or 81.50804-6018	1	

* Replacement must always occur per axle!



Model
L 2000
L 20-25
L 33-36
M 2000-L
L 70-73

for identification:
Chassis number
MWA **L70** zzz yyyy

Front and rear axle: Sliding calliper compressed-air disc brake PAN 17

Spare Parts List 40 175 080 / 081

Description	WABCO number	MAN number	Pieces	Note
Brake	40 175 080	81.50804-6355	1	left brake
Brake	40 175 081	81.50804-6354	1	right brake
Replacement for:				
Brake	40 175 051	81.50804-6089	1	left brake
Brake	40 175 052	81.50804-6090	1	right brake
Replacement for:				
Brake	40 175 027	81.50804-6073	1	left brake
Brake	40 175 028	81.50804-6072	1	right brake
Disc brake pads repair kit normal strength	12 999 782	81.50820-6042	1	per axle*
Contents: Brake linings, Replacement for	12 999 667VT	81.50820-6020		
leaf springs, shackle, screw, Replacement for	12 999 577VT	81.50820-6006		
sealing plug				
Disc brake pads repair kit oversize	12 999 802	81.50820-6053	1	per axle*
Contents: Brake linings, Replacement for	12 999 668VT	81.50820-6021		
leaf springs, shackle, screw, Replacement for	12 999 581VT	81.50820-6007		
sealing plug				
Seals repair kit	12 999 580VT	81.50822-6003	1	per brake
Contents: Sealings, screws, sealing plug				
Exchange brake (without brake pads)	40 175 049	81.50804-9087	1	left brake
	40 175 050	81.50804-9088	1	right brake
	40 175 025	81.50804-9071	1	left brake
Replacement for		or		
	40 175 026	81.50804-6071	1	right brake
		81.50804-9070		
		or		
		81.50804-6070		
Wear indicator	12 480 021	81.50822-6014	1	per brake
Repair kit sealings actuating unit	640 175 920 2		1	per brake
Contents: Sealings, sealing plugs				
Tool box	12 851 022		1	

* Replacement must always occur per axle!

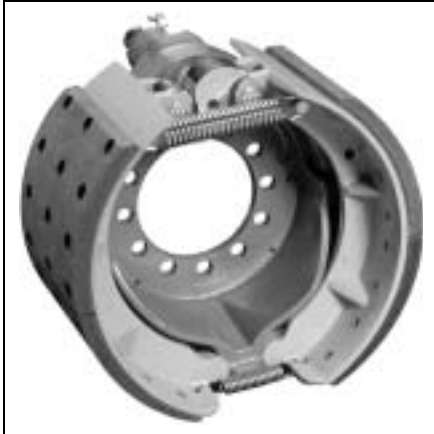

Model
Jetliner
N 416
Jetliner / Low- floor buses
N 4007 NF
N 4009 NF
N 4009 LNF
N 4014 NF
N 4016 NF
N 4021 NF

Front Axle:
Mechanical Simplex Drum Brake (S-Cam Brake) 410 × 160 Z-G

Spare Parts List 10 410 282/283

Description	WABCO number	NEOPLAN number	Pieces	Note
Brake*	10 410 282	0801 672 00	1	left brake
Brake*	10 410 283	0801 673 00	1	right brake
Brake*	10 410 578	0821 325 00	1	left brake
Brake*	10 410 579	0821 326 00	1	right brake
Brake*	10 410 580	0821 373 00	1	left brake
Brake*	10 410 581	0821 374 00	1	right brake
Wear indicator	13 480 048	0803 508 06	1	per brake
Ring	13 701 083		1	per brake
Roller repair kit Contents: Roller, bolts, washer	12 999 112VT	0803 515 00	1	per brake
Seals repair kit Contents: Rotary shaft seals, bushes, washer, ring	12 999 121VT	0803 519 00	1	per brake
Springs repair kit Contents: Tension springs	12 999 114VT	0703 535 00	1	per brake*

* Complete brakes are no longer available.



Model

Jetliner from 1992
N 4008 / 4009 / 4010/4011
N 4014 / 4016 / 4024/4026

Jetliner / Low-floor buses
N 4008 NF / 4009 NF /
N 4009 L NL / 4014 NF
N 4016 NF / 4021 NF

Skyliner from 1992
N 212 H/213 H and SHD,
N 214 H and SHD, N 416 from 1983

Spaceliner from 1992
N 117/2 and 117/3

Transliner from 1992
N 312 / 314 / 316L

Cityliner from 1992
N116/2, N 116H, 116H/3

Rear axle:
Mechanical Simplex Drum Brake (S-Cam Brake) 410 × 220 Z-G

Spare Parts List 10 410 658/659

Description	WABCO number	NEOPLAN number	Pieces	Note
Brake*	10 410 658	0501 004 939	1	left brake
Brake*	10 410 659	0501 004 940	1	right brake
Brake shoe without lining Steel brake shoes	12 155 403VT	1101 431 7	2	per brake**
Brake shoe with lining (turned) Cast brake shoes	12 258 527VT	1101 330 9	2	per brake**
Roller repair kit Steel brake shoes	12 999 112VT	0803 515 00	1	per brake
Contents: Roller, bolts, washer Cast brake shoes	12 999 520VT	1101 152 30	1	per brake
Seals repair kit	12 999 123VT	0821 303 00	1	per brake
Contents: Rotary shaft seals, bushes, washer, ring				
Springs repair kit	12 999 114VT	0703 535 00	1	per brake**
Contents: Tension springs				
Brake shaft	13 161 334VT	0703 530 00	1	left brake
Brake shaft	13 161 335VT	0703 530 01	1	right brake

* Complete brakes are no longer available.

** Replacement must always occur per axle!

Spare Parts List 10 410 664/665

Description	WABCO number	NEOPLAN number	Pieces	Note
Brake*	10 410 664	0501 004 933	1	left brake
Brake*	10 410 665	0501 004 934	1	right brake
Brake shoe with lining (turned)	12 258 689VT	–	2	per brake**
Brake pad repair kit Contents: Pads and rivet	12 999 639VT	–	1	per axle**
Roller repair kit Contents: Roller, bolts, washer	12 999 002VT	0803 515 00	1	per brake
Steel brake shoes Cast brake shoes	12 999 528VT	1101 403 2	1	per brake
Seals repair kit Contents: Rotary shaft seal, bush, washer, ring	12 999 213VT	1101 399 9	1	per brake
Springs repair kit Contents: Tension springs	12 999 003VT		1	per brake**

* Complete brakes are no longer available.

** Replacement must always occur per axle!



Model
N 8008
Metroliner
MIC 4008
MIC 4012
MIC 4017

Front and rear axle: Sliding calliper compressed-air disc brake 1000 V-G

Spare Parts List 40 100 003 /004

Description	WABCO number	NEOPLAN number	Pieces	Note
Brake	40 100 003	0821.321.40	1	front axle right, rear axle left
Brake	40 100 004	0821.322.40	1	front axle left, rear axle right
Disc brake pads repair kit normal strength Contents: Brake linings, leaf springs, pins, sealing plug	12 999 631VT	0823.311.00	1	per axle*
Disc brake pads repair kit oversize Contents: Brake linings, leaf springs, pins, sealing plug	12 999 632VT		1	per axle*
Guide bolts and seals repair kit Contents: Guide pins, shaft sealing ring, cover, protection caps, bushings, leaf springs, screws	12 999 729VT	0821.392.00	1	per axle

* Replacement must always occur per axle!



Model

Midlum M 112
7,5-12 t

Front and rear axle: Sliding calliper compressed-air disc brake PAN 17

Spare Parts List 40 175 062/063

Description	WABCO number	Renault number	Pieces	Note
Brake (from 04/2000)	40 175 062	5010422260	1	left brake
Brake (from 04/2000)	40 175 063	5010422261	1	right brake
Brake pads repair kit Contents: Brake linings, hold-down springs, hold-down screws, retainer, sealing plugs, wear indicators, casing clamps	12 999 703VT	5010848607	1	per axle*
Repair kit of seals and guide bolts Contents: Protection caps, cheese head screws, guide pins, sealings, bushings	12 999 704VT	5001852880	1	per brake
Exchange brake (without pads)	40 175 064 40 175 065	5001852882 5001852883	1 1	left brake right brake
Repair kit sealings actuating unit Contents: Sealings, sealing plugs	640 175 920 2		1	per brake
Tool box	12 851 022		1	

* Replacement must always occur per axle!



Model
Midlum M 113 14-16 t

Front and rear axle: Sliding calliper compressed-air disc brake PAN 19-2

Spare Parts List 40 195 009/010

Description	WABCO number	Renault number	Pieces	Note
Brake (from 05/2001)	40 195 009	5010525012	1	left brake
Brake (from 05/2001)	40 195 010	5010525013	1	right brake
Brake pads repair kit Contents: Brake linings, hold-down springs, hold-down screws, retainer, sealing plugs, wear indicators, casing clamps	12 999 747VT	5001855902	1	per axle*
Repair kit of seals and guide bolts Contents: Protection caps, cheese head screws, guide pins, sealings, bushings	12 999 746VT	5001858722	1	per brake
Exchange brake (without disc brake pads)	40 195 021	5001858720	1	left brake
	40 195 022	5001858721	1	right brake
Tool box	12 851 021		1	

* Replacement must always occur per axle!



Trailer vehicles and others

FUWA

Gigant group

IMT

TMC

TOUGHLINE

York

Sliding calliper compressed-air disc brake PAN 19-1^{plus}

Spare Parts List 40 195 027/028

Description	WABCO number	Pieces	Note
Brake	40 195 027	1	left brake
Brake	40 195 028	1	right brake
Brake pads repair kit Contents: Brake linings, hold down springs, hold-down screws, retainer, sealing plug	12 999 737VT 640 195 924 2	1	per axle*
Wear indicator repair kit Contents: Wear indicator, casing clamps	12 999 755VT	1	per axle
Repair kit of seals and guide bolts Contents: Wear plug, protection cap, screws, cover, bushings, pins, sealings, (white/green)	12 999 738VT	1	per brake
Clamping unit repair kit Contents: Sealings, sealing plugs	640 175 920 2	1	per brake
Retro-fit kit wear indicator for TEBS-D Contents: Wear indicators, casing clamps, cables, connectors	480 102 920 2 480 102 921 2	1 1	1-, 2- and 3-axle semitrailers** 2-axle drawbar trailers**
Exchange brake PAN 19-1 / PAN 19-1 ^{plus} (without disc brake pads)	40 195 037 40 195 038	1 1	left brake right brake
Tool box	12 851 021	1	

* Replacement must always occur per axle!

** per trailer



Trailer vehicles and others

FAW

GFA vehicle axles

Gigant group

IMT

TMC

TOUGHLINE

York

Sliding calliper compressed-air disc brake PAN 22-1

Spare parts list 40 225 011/012

Description	WABCO number	Pieces	Note
Brake	40 225 011	1	left brake
Brake	40 225 012	1	right brake
Brake pads repair kit Contents: Brake linings, hold down springs, hold-down screws, retainer, sealing plug	12 999 796 640 225 920 2	1	per axle*
Wear indicator repair kit Contents: Wear indicator, casing clamps	12 999 797	1	per axle
Repair kit of seals and guide bolts Contents: Protection caps, cheese head screws, guide pins, sealings (white/green), bushings	12 999 738VT	1	per brake
Clamping unit repair kit Contents: Sealings, sealing plugs	640 175 920 2	1	per brake
Retro-fit kit wear indicator for TEBS-D Contents: Wear indicators, casing clamps, cables, connectors	480 102 924 2 480 102 925 2	1 1	1-, 2- and 3-axle semitrailers** 2-axle drawbar trailers**
Exchange brake PAN 22-1 (without disc brake pads)	40 225 015 40 225 016	1 1	left brake right brake
Tool box	12 851 021	1	

* Replacement must always occur per axle!

** per trailer

PAN 19-1^{plus}
6-hole support

Trailer wheel axle SAF
Axle: SAF SKRB 9019 W Intradisc plus

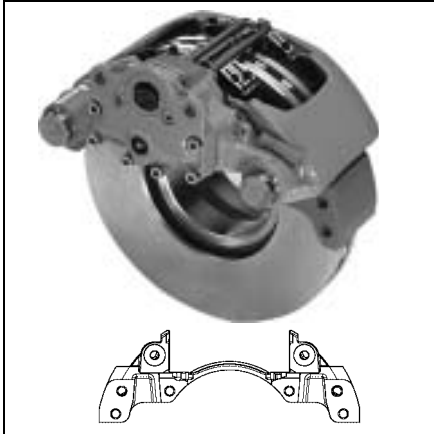

Semi-trailers

- KEMPF

- KÖGEL

- KRONE

- Schwarzmüller

Single tyre ET120, 9 t:
SKRB 9019 W, SKRB 9019 WI

Single tyre ET0, 9 t:
SKRS 9019 W

Dual tyres 9 t (only AUS / NZ):
SKRZ 9019 W

Sliding calliper compressed-air disc brake PAN 19-1^{plus}

Spare Parts List 40 195 017/018 / PAN 19-1^{plus} / from 2002
40 195 001/002 / PAN 19-1 / from 2000

Description	WABCO number	SAF number	Pieces	Note
Brake (from 03/2002)	40 195 017	3.080.0033.20	1	left brake
Brake (from 03/2002)	40 195 018	3.080.0032.20	1	right brake
replacement for				
Brake (from 02/2000–03/2002)	40 195 001	3.080.0019.01	1	left brake
Brake (from 02/2000–03/2002)	40 195 002	3.080.0018.01	1	right brake
Brake incl. wear indicator	40 195 035	3.080.0035.20	1	left brake
Brake incl. wear indicator	40 195 036	3.080.0034.20	1	right brake
Brake pads repair kit	12 999 737VT	3.057.0080.00	1	per axle*
Contents: Brake linings, hold down springs, hold-down screws, retainer, sealing plug	640 195 924 2			
Wear indicator repair kit	12 999 755VT	3.424.2001.00	1	per axle
Contents: Wear indicator, casing clamps				
Repair kit of seals and guide bolts	12 999 738VT	3.434.3827.01	1	per brake
Contents: Wear plug, protection cap, screws, cover, bushings, pins, sealings, (white/green)				PAN 19-1 PAN 19-1 ^{plus} PAN 22-1
Clamping unit repair kit	640 175 920 2	3.434.3829.00	1	per brake
Contents: Sealings, sealing plugs				
Retro-fit kit wear indicator for TEBS-D	480 102 920 2		1	1-, 2- and 3-axle
Contents: Wear indicators, casing clamps, cables, connectors	480 102 921 2		1	semitrailers** 2-axle drawbar trailers**
Exchange brake PAN 19-1 / PAN 19-1 ^{plus} (without disc brake pads)	40 195 037 40 195 038		1 1	left brake right brake
Tool box	12 851 021	3.434.6010.00	1	

* Replacement must always occur per axle!

** per trailer

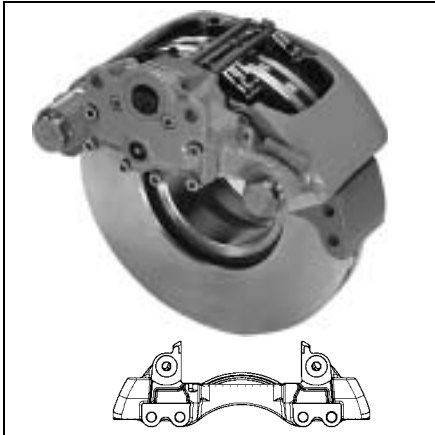

Semi-trailers

KEMPF

KÖGEL

KRONE

Schwarzmüller

Single tyre ET120, 9 t:
B9-19W, BI9-19W

Single tyre ET0, 9 t:
SI9-19 W (from 10/2007)

Dual tyres 9 t (only AUS / NZ):
ZI9-19 W (from 10/2007)

Sliding calliper compressed-air disc brake PAN 19-1^{plus}

Spare parts list 640 195 068 0/069 0 (from 2007)

Description	WABCO number	SAF number	Pieces	Note
Brake	640 195 068 0	3.080.0071.21	1	left brake
Brake	640 195 069 0	3.080.0072.21	1	right brake
Brake incl. wear indicator	640 195 074 0	3.080.0073.20	1	left brake
Brake incl. wear indicator	640 195 075 0	3.080.0074.20	1	right brake
Brake pads repair kit Contents: Brake linings, hold down springs, hold-down screws, retainer, sealing plug	12 999 737VT 640 195 924 2	3.057.0080.00	1	per axle*
Wear indicator repair kit Contents: Wear indicator, casing clamps	12 999 755VT	3.424.2001.00	1	per axle
Repair kit of seals and guide bolts Contents: Wear plug, protection cap, screws, cover, bushings, pins, sealings, (white/green)	12 999 738VT	3.434.3827.01	1	per brake PAN 19-1 PAN 19-1 ^{plus} PAN 22-1
Clamping unit repair kit Contents: Sealings, sealing plugs	640 175 920 2	3.434.3829.00	1	per brake
Retro-fit kit wear indicator for TEBS-D Contents: Wear indicators, casing clamps, cables, connectors	480 102 920 2 480 102 921 2		1 1	1-, 2- and 3-axle semitrailers** 2-axle drawbar trailers**
Exchange brake PAN 19-1 / PAN 19-1 ^{plus} (without disc brake pads)	640 195 071 0 640 195 072 0		1 1	left brake right brake
Tool box	12 851 021	3.434.6010.00	1	

* Replacement must always occur per axle!

** per trailer

PAN 22-1
6-hole support

Trailer wheel axle SAF

9 t axle: SKRS 9022W, SKR(L)B 9022W, SKRZ 9022W
11 t axle: SKRS 11222W, SKRZ 11222

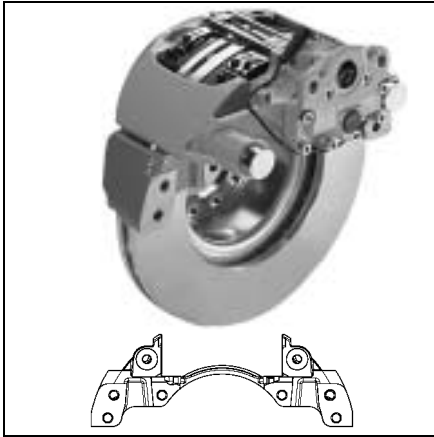

Semi-trailers

- Kempf

- Kögel

- Krone

- Schwarzmüller

Single tyre ET120, 9 t:
SKRB 9022 W, SKRB 9022 WI

Single tyre ET0, 9 t:
SKRS 9022 W

Single tyre ET0, 11 t:
SKRS 11222 W

Dual tyres 9 t:
SKRZ 9022 W

Dual tyres 11 t:
SKRZ 11222 W

Sliding calliper compressed-air disc brake PAN 22-1

Spare Parts List 40 225 007/008

Description	WABCO number	SAF number	Pieces	Note
Brake	40 225 007	3.080.0051.20	1	left brake
Brake	40 225 008	3.080.0050.20	1	right brake
Brake pads repair kit Contents: Brake linings, hold down springs, hold-down screws, retainer, sealing plug	12 999 796 640 225 920 2	3.057.0084.00	1	per axle*
Wear indicator repair kit Contents: Wear indicator, casing clamps	12 999 797	3.424.2009.00	1	per axle
Repair kit of seals and guide bolts Contents: Protection caps, cheese head screws, guide pins, sealings (white/green), bushings	12 999 738VT	3.434.3827.01	1	per brake
Clamping unit repair kit Contents: Sealings, sealing plugs	640 175 920 2	3.434.3829.00	1	per brake
Retro-fit kit wear indicator for TEBS-D Contents: Wear indicators, casing clamps, cables, connectors	480 102 924 2 480 102 925 2		1 1	1-, 2- and 3-axle semitrailers** 2-axle drawbar trailers**
Exchange brake PAN 22-1 (without disc brake pads)	40 225 015 40 225 016		1 1	left brake right brake
Tool box	12 851 021	3.434.6010.00	1	

* Replacement must always occur per axle!

** per trailer

Trailer wheel axle SAF

9 t axle: SKRS 9022W, SKR(L)B 9022W, SKRZ 9022W
 11 t axle: SKRS 11222W, SKRZ 11222

PAN 22-1
 4-hole support

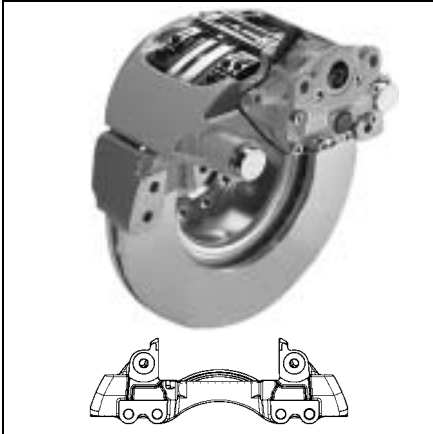

Semi-trailers

KEMPF

KÖGEL

KRONE

Schwarz Müller

Single tyre ET120, 9 t:
 B9-22W, BI9-22W

Single tyre ET0, 9 t:
 SI9-22W (from 10/2007)

Single tyre ET0, 11 t:
 SI11-22W (from 10/2007)

Dual tyres 9 t:
 ZI9-22W (from 10/2007)

Dual tyres 11 t:
 ZI11-22W (from 10/2007)

Sliding calliper compressed-air disc brake PAN 22-1

Spare parts list 640 225 022 0/023 0 (from 2007)

Description	WABCO number	SAF number	Pieces	Note
Brake	640 225 022 0	3.080.0067.20	1	left brake
Brake	640 225 023 0	3.080.0068.20	1	right brake
Brake pads repair kit Contents: Brake linings, hold down springs, hold-down screws, retainer, sealing plug	12 999 796 640 225 920 2	3.057.0084.00	1	per axle*
Wear indicator repair kit Contents: Wear indicator, casing clamps	12 999 797	3.424.2009.00	1	per axle
Repair kit of seals and guide bolts Contents: Protection caps, cheese head screws, guide pins, sealings (white/green), bushings	12 999 738VT	3.434.3827.01	1	per brake
Clamping unit repair kit Contents: Sealings, sealing plugs	640 175 920 2	3.434.3829.00	1	per brake
Retro-fit kit wear indicator Contents: Wear indicators, casing clamps, cables, connectors	480 102 924 2 480 102 925 2		1 1	1-, 2- and 3-axle semitrailers** 2-axle drawbar trailers**
Exchange brake PAN 22-1 (without disc brake pads)	640 225 025 0 640 225 026 0		1 1	left brake right brake
Tool box	12 851 021	3.434.6010.00	1	

* Replacement must always occur per axle!

** per trailer



Sliding calliper compressed-air disc brake PAN 19-1^{plus}

Spare parts list 40 195 055/056

Description	WABCO number	SAMRO number	Pieces	Note
Brake	40 195 055	–	1	left brake
Brake	40 195 056	–	1	right brake
Brake pads repair kit Contents: Brake linings, hold down springs, hold-down screws, retainer, sealing plug	12 999 777	–	1	per axle* including wear indicator
Repair kit of seals and guide bolts Contents: Wear plug, protection cap, screws, cover, bushings, pins, sealings	12 999 776	–	1	per brake
Clamping unit repair kit Contents: Sealings, sealing plugs	640 175 920 2	–	1	per brake
Replacement brake PAN 19-1 ^{plus} (without disc brake pads)	40 195 045 40 195 046	–	1 1	left brake right brake
Tool box	12 851 021	–	1	

* Replacement must always occur per axle!



Semi-trailers

Schmitz-

Sliding calliper compressed-air disc brake PAN 22-1

Spare parts list 6 40 225 030 0/031 0

Description	WABCO number	Schmitz number	Pieces	Note
Brake	640 225 030 0	SCB 1035 094	1	left brake
Brake	640 225 031 0	SCB 1035 095	1	right brake
Brake pads repair kit Contents: Brake linings, hold down springs, hold-down screws, retainer, sealing plug	640 225 922 2 640 225 920 2	SCB 1068 118	1	per axle*
Wear indicator repair kit Contents: Wear indicator, casing clamps	12 999 797	SCB 1067 145	1	per axle
Repair kit of seals and guide bolts Contents: Wear plug, protection cap, screws, cover, bushings, pins, sealings	12 999 776	SCB 1068 119	1	per brake
Clamping unit repair kit Contents: Sealings, sealing plugs	640 175 920 2	SCB 1068 160	1	per brake
Exchange brake PAN 22-1 (without disc brake pads)	640 225 040 0 640 225 041 0	SCB 1068 161 SCB 1068 162	1 1	left brake right brake
Tool box	12 851 021	SCB 1068 178	1	

* Replacement must always occur per axle!



Semi-trailers

- Benalu

- Fruehauf

- Trailor

- Blond-Baudoin

Sliding calliper compressed-air disc brake PAN 22-2

Spare Parts List 40 225 003 /004

Description	WABCO number	SMB number	Pieces	Note
Brake	40 225 003	M069999	1	left brake
Brake	40 225 004	M070008	1	right brake
Brake pads repair kit Contents: Brake linings, leaf springs, sealing plugs, shackle, screws	12 999 676VT	M100669	1	per axle*
Seals repair kit Contents: Sealing plug, protection caps, bushings, screws, cover	12 999 677VT	M100667	1	per brake
Guide shaft repair kit Contents: Protection caps, screws, cover, bushings, pins	12 999 678VT	M100675	1	per brake
Brake disc	13 162 025	M069018	1	per brake

* Replacement must always occur per axle!

Cranes

Liebherr, Krupp, Mannesmann-Dematic, Tadano-Faun etc.

410 × 180 ZE



Simplex Expanding Wedge Drum Brake 410 × 180 ZE

Spare Parts list 410 × 180 ZE

Description	WABCO number	Pieces	Note
Brake	10 410 777	1	
Brake shoes with pad*	12 258 512VT	2	per brake***
Brake	10 410 849	1	
Brake shoes with pad**	12 258 658VT	1	per brake***
	12 258 659VT	1	per brake***
Tension spring for brake 10 410 777	13 301 161	2	per brake***
Tension spring for brake 10 410 849	13 301 255	2	per brake***
Expander	12 739 085VT	1	per brake
Adjuster repair kit Contents: Ring, nut, screws, compression spring	12 999 292VT	1	per brake
Wedge repair kit Contents: Wedge, piston	12 999 518VT	1	per brake
Seals repair kit Contents: Sealings, protection caps	12 999 453VT	1	per brake

* bonded and riveted with 16 rivets

** only riveted with 16 rivets

*** Replacement must always occur per axle!

Info for expander units:

Housing number 14 352 022 – repair kits wedge and adjustment are no longer available. Please use the complete wedge unit.



Duplex Expanding Wedge Drum Brake 410 × 180 DE

Spare Parts List 410 × 180 DE

Description	WABCO number	Pieces	Note
Brake	10 410 769	1	left brake
Brake	10 410 770	1	right brake
Brake shoes with pad*	12 258 510VT	2	per brake***
Brake	10 410 850	1	left brake
Brake	10 410 851	1	right brake
Brake shoes with pad**	12 258 660VT	2	per brake***
Tension spring for Brakes 10 410 769 / 770	13 301 161	2	per brake***
Tension spring for Brakes 10 410 850 / 851	13 301 255	2	per brake***
Pressure spring	13 302 008	2	per brake***
Expander	12 739 086VT	2	per brake
Adjuster repair kit Contents: Ring, nut, screws, compression spring	12 999 295VT	1	per wedge unit
Wedge repair kit Contents: Wedge, piston	12 999 519VT	1	per wedge unit
Seals repair kit Contents: Sealings, protection caps	12 999 453VT	1	per wedge unit

* bonded and riveted with 16 rivets
 ** only riveted with 16 rivets
 *** Replacement must always occur per axle!

Info for expander units:

Housing number 14 352 022 – repair kits wedge and adjustment are no longer available. Please use the complete wedge unit.



Simplex Expanding Wedge Drum Brake 500 × 120 ZE

Spare Parts list 500 × 120 ZE

Description	WABCO number	Pieces	Note
Brake	10 500 729	1	
Brake	10 500 770	1	
Brake shoes with pad*	12 258 387VT	2	per brake***
Brake	10 500 775	1	
Brake shoes with pad**	12 258 602VT	2	per brake***
Brake	10 500 779	1	
Brake	10 500 789	1	
Brake shoes with pad**	12 258 669VT	2	per brake***
Tension spring	13 301 258	2	per brake***
Expander	12 739 085VT	1	per brake
Adjuster repair kit Contents: Ring, nut, screws, compression spring	12 999 292VT	1	per brake
Wedge repair kit Contents: Wedge, piston	12 999 518VT	1	per brake
Seals repair kit Contents: Sealings, protection caps	12 999 453VT	1	per brake

* bonded and riveted with 16 rivets

** only riveted with 16 rivets

*** Replacement must always occur per axle!

Info for expander units:

Housing number 14 352 022 – repair kits wedge and adjustment are no longer available. Please use the complete wedge unit.



Simplex Expanding Wedge Drum Brake 500 × 160 ZE

Spare Parts list 500 × 160 ZE

Description	WABCO number	Pieces	Note
Brake*	10 500 728	1	
Brake*	10 500 769	1	
Brake	10 500 771	1	
Brake shoes with pad**	12 258 378VT	2	per brake****
Brake	10 500 774	1	
Brake shoes with lining***	12 258 597VT	2	per brake****
Brake	10 500 780	1	
Brake	10 500 783	1	
Brake shoes with lining***	12 258 652VT	2	per brake****
Tension spring	13 301 258	2	per brake
Expander	12 739 085VT	1	per brake
Adjuster repair kit Contents: Ring, nut, screws, compression spring, pin	12 999 292VT	1	per brake
Wedge repair kit Contents: Wedge, piston	12 999 518VT	1	per brake
Seals repair kit Contents: Seals, protective cap	12 999 453VT	1	per brake

* Complete brake is no longer available.

** bonded and riveted with 16 rivets

*** only riveted with 16 rivets

**** Replacement must always occur per axle!

Info for expander units:

Housing number 14 352 022 – repair kits wedge and adjustment are no longer available. Please use the complete wedge unit.

Cranes

Liebherr, Krupp, Mannesmann-Dematic, Tadano-Faun etc.

500 × 180 DE



Duplex Expanding Wedge Drum Brake 500 × 180 DE

Spare Parts List 500 × 180 DE

Description	WABCO number	Pieces	Note
Brake	10 500 726	1	left brake
Brake	10 500 727	1	right brake
Brake shoes with pad*	12 258 384VT	2	per brake***
Brake	10 500 772	1	left brake
Brake	10 500 773	1	right brake
Brake	10 500 776	1	left brake
Brake	10 500 777	1	right brake
Brake shoes with pad**	12 258 591VT	2	per brake***
Brake	10 500 784	1	left brake
Brake	10 500 785	1	right brake
Brake shoes with pad**	12 258 651VT	2	per brake***
Tension spring	13 301 161	2	per brake***
Pressure spring	13 302 008	2	per brake***
Expander	12 739 086VT	2	per brake
Adjuster repair kit Contents: Ring, nut, screws, compression spring, pin	12 999 295VT	2	per wedge unit
Wedge repair kit Contents: Wedge, piston	12 999 519VT	2	per wedge unit
Seals repair kit Contents: Seals, protective cap	12 999 453VT	2	per wedge unit

* bonded and riveted with 16 rivets

** new reinforced construction, only riveted with 28 rivets (500 × 180 DE)

*** Replacement must always occur per axle!

Info for expander units:

Housing number 14 352 022 – repair kits wedge and adjustment are no longer available. Please use the complete wedge unit.



Front and rear axles: Sliding Calliper Disc Brake PAN 25

Spare parts list 640 250 004 0/005 0

Description	WABCO number	Pieces	Note
Brake	640 250 004 0*	1	left brake
Brake	640 250 005 0*	1	right brake
Brake pads repair kit Contents: Brake linings, hold-down springs, hold-down screws, retainer, sealing plugs, wear indicators, casing clamps	640 250 921 2	1 2	per axle with 2 brakes** per axle with 4 brakes** including wear indicators
Guide bolts and seals repair kit Contents: Sealing plug, protection caps, screws, cover, pins	12 999 738VT	1	per brake
Clamping unit repair kit Contents: Sealings, sealing plugs	640 175 920 2	1	per brake
Brake disc repair kit	640 250 920 2*	1	per brake
Tool box	12 851 021	1	

* Obtained via company Kessler, Abtsgmünd

** Replacement must always occur per axle!

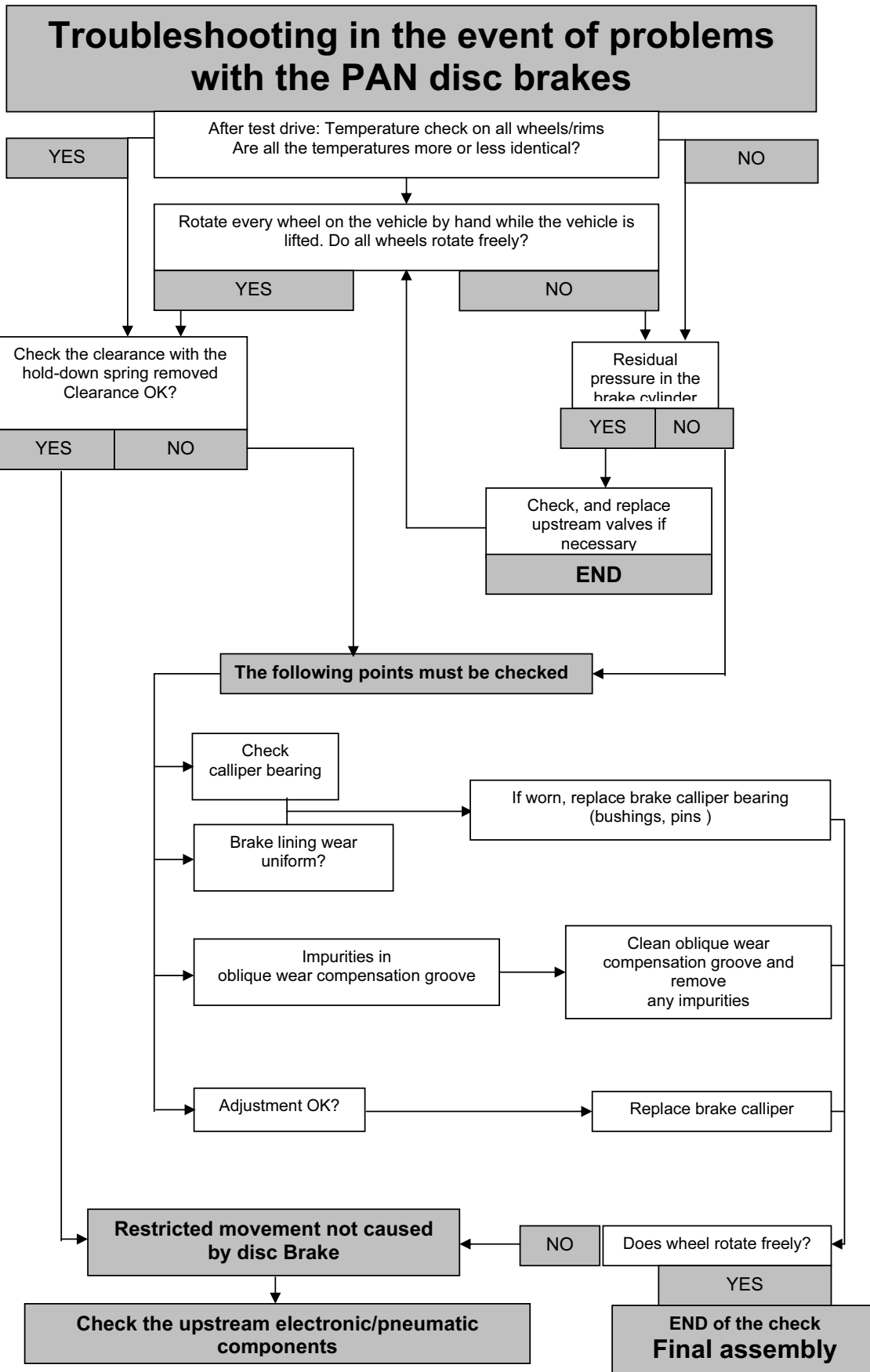

These instructions are merely designed to assist the troubleshooting procedure. There may be deviations depending on the vehicle design or the vehicle manufacturer. No liability can therefore be accepted for the correctness of these instructions.

Necessary work after fitting new brake linings

- Turn the hexagon nut of the adjuster nut SW 10 until both brake brake linings contact the brake disc. The turning direction to adjust the adjustment is in the direction of operation of the brake lever. (Return of the automatic adjustment: turning direction against the direction of operation).
- Unscrew adjuster nut by ½ turn and move the brake calliper in direction to the wheel till the pad on the brake operation side touches the disc.
- Adjust clearance to 1 mm - 0.1 mm between lining backplate and calliper housing on the rim side using a feeler gauge. Fine adjusting of the brake clearance is done by the automatic adjustment device of the brake.
- Place leaf springs onto the brake lining plate.
- Do not fit pad hold down pin before adjusting air gap.
- Push springs against the brake pad and drive pad hold down pin into the calliper from the wheel side. Control: The clamping sleeve of the pad hold down pin sits in the calliper half on the wheel side.
- Push rubber plug into the opening of the brake shaft.
- Ensure that the wheel hub turns freely.

Important notes

- Every time the brake pads are changed, fit new leaf springs, lining retainer pin, and sealing plug.
- Ensure that the brake is not dragging. For this purpose, jack up and turn the wheel by hand.
- Push rubber plug into the opening of the brake shaft. This is vital since otherwise moisture will penetrate into the clamping mechanism causing corrosion.
- When fitting the clevis pin (cylinder push rod / brake lever), the hole in the clevis must align with the hole in the brake lever in its fully returned position. Never turn the brake lever to obtain alignment, if necessary adjust the linkage. Following a brake application, the lever must return to its original position, otherwise the automatic adjuster will not function properly.
- Any damaged rubber parts must be replaced immediately.

Necessary work after fitting new brake linings

- Adjust the brake on the hexagon head with over flats 8 mm, of the adjuster nut until both brake pads are clamped against the brake disc.
- The direction of rotation for adjusting of the adjustment nut is anti clockwise. The direction of rotation for readjusting of the automatic adjustment device is clockwise.
- Readjust the adjustment device for $\frac{1}{4}$ rotation, and move the brake calliper in direction to the wheel till the pad on the operation side rests on the disc.
- Adjust clearance to 1 – - 0.1 mm between lining backplate and calliper section on the rim side using a feeler gauge. Fine adjusting of the brake clearance is alone by the automatic adjustment device of the brake.
- Insert pad hold down springs on the pads and pressure plate.
- Do not fit pad hold down pin before adjusting air gap.
- Insert pad hold down strap plate into the holes in the calliper and push down in the way that the hold down springs engage into the hold down strap.
- Tighten hexagon head screw for the retainer on the brake calliper with the specified tightening torque (20 +/- 2 Nm. Use a 17 AF spanner.
- Push new rubber plug into the adjuster hole in the brake calliper. This is vital since otherwise moisture will penetrate into the clamping mechanism causing corrosion (risk of corrosion). (risk of corrosion)
- Ensure that the wheel hub turns freely.

Important notes

- To avoid damaging the protection caps it must be ensured that the pressure plate is seated in the brake anchor plate guide during the reset (moving back by hand). During this process the pin of the adjustment screw must mesh with the elongated hole of the pressure plate.
- Any damaged rubber parts must be replaced immediately.
- Use only original WABCO repair kits.
- It is essential to avoid actuating the wheel brakes while the brake linings are removed. Engaging the actuation or parking brake subjects the workshop employee to the risk of injury. Another possible consequence of actuating the brake without fitted linings is damage to the mechanics of the brake and/or the brake cylinder leading to reduced braking force. For that reason please attach a visible warning note on the steering wheel when working on the brake system.

Expanding wedge drum brake

Basic Settings of Wheel Brakes

- Carefully remove the gaiter from the annular groove in the housing.
 - Withdraw adjuster screw with the adjuster nut and the gaiter from the piston.
 - Screw adjuster nut onto adjuster screw until it contacts with the screw's collar, i. e. the nut cannot be turned any further.
 - Unscrew adjuster screw by 3 whole turns ($3 \times 360^\circ$) to ensure proper adjuster.
- base of the piston, thereby preventing engagement of the teeth between the adjuster ring and the adjuster nut, which will lead to failure of the automatic adjuster.
- Replace complete unit into the piston, making sure the gaiter is properly seated.
 - Repeat these steps for the second adjuster mechanism (Simplex brake).
 - Actuate brake 15 to 20 times in order that the design clearance of the brake is automatically adjusted.

Important

If these directions are not followed, the adjuster screw will touch the

Important notes

- With a Simplex brake, both adjuster screws of the expander must always be unscrewed from the adjuster nuts by the same amount to ensure that the brake shoes are centralized.
- With a Duplex brake, the adjuster screws of both expander units must be unscrewed out of the adjuster nuts by the same amount to ensure that the brake shoes are centralized.
- When carrying out maintenance work, check all seals for damage and replace as necessary.

Type designation for WABCO Wheel Brakes

Disk Brakes

Size:	number of pistons and piston diameter or braking torque
Type:	fixed calliper brake = F (fixed) floating calliper brake = V (floating) jaw brake = T (Transmission)
Actuation:	hydraulic = Ö (oil pressure) mechanical = G (linkage)
Example:	Typ 444 F-Ö or Typ 1000 V-G
Exception:	PAN 17/19/22/25 PERROT Axial New and wheel diameter in inches

Drum Brakes

Size:	Brake diameter x width of brake shoes
Type:	Simplex-Brake = Z Duplex-Brake = D Duo servo brake = S Duo servo brake with centering= SM (common type)
Actuation:	hydraulic = Ö (oil pressure) mechanical = G (linkage) expanding wedge = E (expander) mechanical actuation = m
Example:	325 × 100 Z-Öm
Exception:	410 × 200 ZE