

Drehschieberventil

Rotary Slide Valve

463 032



Zweck:

Steuerung des Anhebens und Absenkens von luftgefederten Wechselpritschen- und Sattelanhängen-Fahrgestellen.

Einbauempfehlung:

Das Drehschieberventil ist mit 4 Schrauben M8 senkrecht oder waagrecht einzubauen.

Purpose:

To raise and lower the chassis of air-spring semi-trailers and vehicles with interchangeable platforms.

Installation Requirement:

Using four bolts M8, the Rotary Slide Valve is to be installed either vertically or horizontally. The plate supplied showing the lever positions is to be affixed below the handle.

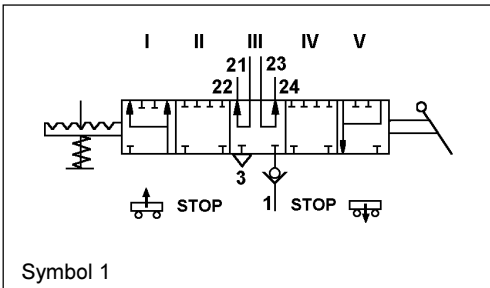

Symbol 1

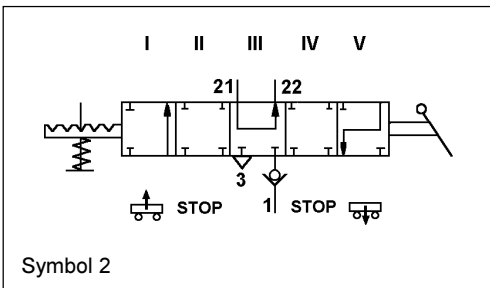

Symbol 2

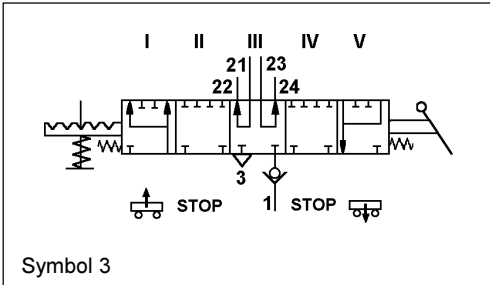

Symbol 3

Einbaumaße / Installation:

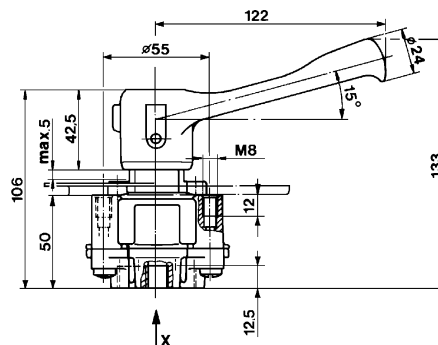

Anschlüsse / Ports:

- 1= Energiezufuß
Energy supply
- 22,24= zum Luftfederbalg
to air suspension bellow
- 21,23= zum Luftfederventil
to levelling valve

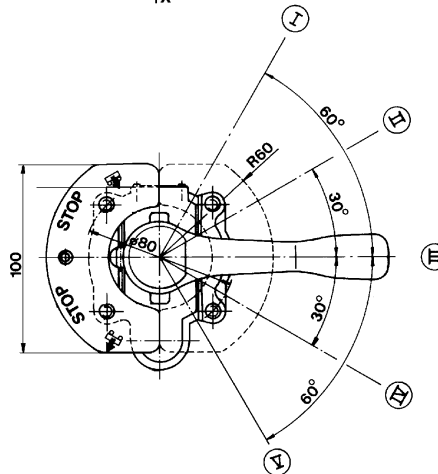

Ansicht: X View: X

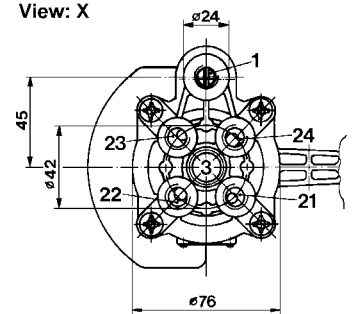

Technische Daten / Technical Data:

Betriebsdruck Operating Pressure	max. 10 bar
Zulässiges Medium Permissible Medium	Luft / air
Therm. Anwendungsber. Oper. temperature range	-40°C bis/to +80°C

Bestellnummer Part Number	Anschlüsse / Ports		Symbol	Bemerkungen / Comments
	1	21;22;23;24		
463 032 020 0	M 16x1,5	M 12x1,5	1	
463 032 022 0	M 12x1,5		1	
463 032 023 0	M 12x1,5		2	ohne Anschluß 23/24 / without Port 23/24
463 032 026 0	M 16x1,5		1	Anschluß 1 ohne Rückschlagventil / Port 1 without Check-Valve
463 032 120 0	M 16x1,5		3	autom. Rücklauf von Heben/Senken nach Stop automatical return from raise / lower to stop